

# Force and Torque Measurement Products



Catalog 21

**MARK-10**

Force and Torque Measurement Engineered Better



# About Mark-10

Mark-10 Corporation is a designer and manufacturer of force and torque measurement products. Since our founding in 1979, our products have proven themselves in numerous applications at companies in the automotive, medical device, textile, pharmaceutical, cosmetic, packaging, food, and many other industries.

## Focus On Engineering

Founded in 1979 as an engineering consultancy, and branching out into contract manufacturing in the 1980s, Mark-10 has focused on better engineering and technical expertise from our very beginning. Having acquired years of expertise in force measurement, we developed our first force gauge in 1990. Our product line has grown significantly since then, including indicators with remote sensors, manual and motorized test stands, a full range of grips and fixtures, along with software and accessories.

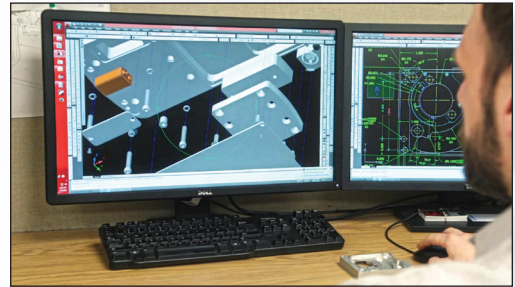

## A Culture of Innovation

As an independent, family-run business, we are free to make decisions that best serve our customers' interests. Through frequent collaboration between Engineering, Manufacturing, Marketing, and Sales, we keep a pulse on the market, and address those needs with products which are elegant, easy to use, and cost effective.



## Integrated Manufacturing

Within the walls of our fully integrated Copiague, NY facility, a product often starts out as a chat over a cup of coffee. Utilizing the latest in CAD technology, CNC machining, and a talented team of technicians and assemblers, product ideas come to life. Technical support and customer service are right down the hallway. With our team under one roof, customer questions and feedback are addressed quickly and accurately.





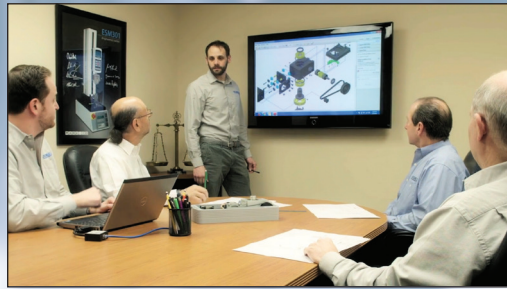



# Industries & Applications



## Medical Device & Pharmaceutical

- Needle penetration force
- Tablet crush force
- Suture strength
- Packaging peel force
- Syringe plunger force
- Tubing connector pull-off force
- Dental and bone screw torque
- Tensile strength of orthodontic wire
- Stopcock torque
- Catheter torque
- Luer lock torque
- Adhesive strength of bandages



## Automotive

- Switch activation force
- Ergonomics / job task analysis
- Rotary dial torque
- Torque tool calibration
- Seat belt retraction force
- Job task analysis
- Fastener torque testing
- Ignition switch torque measurement
- Turn signal stalk activation testing
- Wire terminal crimp pull testing
- Spring testing
- Bearing torque testing
- Coefficient of friction testing
- Windshield wiper arm force



## Springs

- Extension spring testing
- Compression spring testing
- Torsion spring testing



## Aerospace

- Spring testing
- Wire terminal crimp pull testing
- Force and torque testing of dials and switches
- Passenger control button activation force
- Bearing torque testing
- Cable tension testing
- Tensile strength of materials



## Electronics

- Switch force activation
- PCB bend testing
- Wire crimp pull testing
- Component pull-off testing
- Component shear testing
- Peel strength
- Keypad testing
- Connector insertion/withdrawal force





# Industries & Applications



## Packaging

- 90° peel testing of adhesive tapes
- T-peel tests of flexible packaging materials
- 180° peel testing
- Opening force testing
- Score bend testing
- Bottle cap torque testing
- Coefficient of friction testing
- Top-load testing of bottles and cartons
- Foil seal pull-off testing



## Consumer Products & Sports Equipment

- Ski flex testing
- Goggle strap pull testing
- Tennis ball compression testing
- Lace break strength
- Elongation testing of elastomers, plastics, and other materials
- Peel testing of packaging materials
- Wire crimp pull testing
- Spring testing
- Dial torque testing
- Hinge torque testing
- Toy component pull-off testing
- Foam compression testing
- Switch activation force



## Ergonomics & Job Task Analysis

- Pushing a wheelchair or cart
- Loading and unloading boxes
- Luggage / cargo handling
- Operating heavy machinery
- Muscle strength testing
- Fitness assessment
- Lifting boxes
- Pulling items from racks



## Food and Beverage

- Bottle cap torque testing
- Bottle cap pull-off force testing
- Food texture analysis
- Top load testing
- Burst testing
- Crush testing



## General Manufacturing



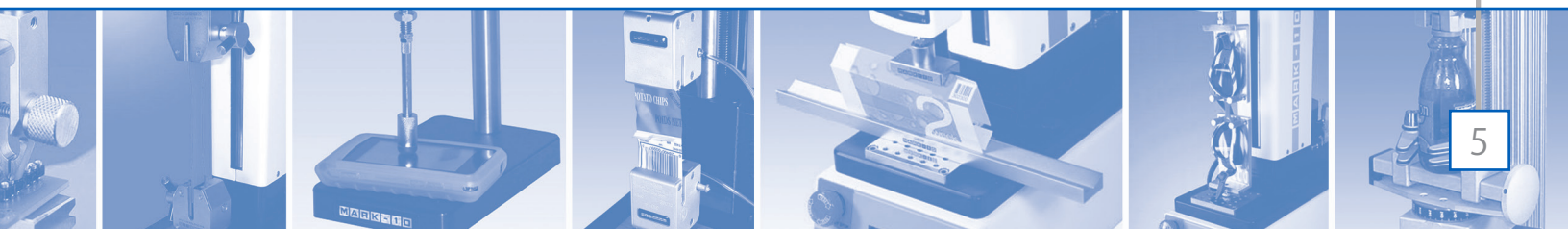



- Spring testing
- Torque tool testing
- Push-out force testing
- Tensile testing
- Hinge torque testing
- Weld force testing
- Elongation testing
- Bearing torque testing



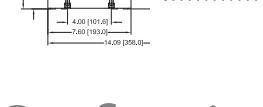

# Welcome to Mark-10

## Table of Contents

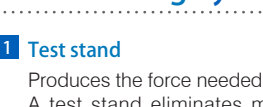
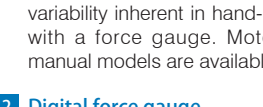
	<b>Digital Force and Torque Gauges</b>	<b>7</b>
	<b>Plug &amp; Test™ Indicators and Remote Sensors</b>	<b>18</b>
	<b>Wire Crimp Pull Testers</b>	<b>24</b>
	<b>Ergonomics Testing Kits</b>	<b>26</b>
	<b>Software</b>	<b>27</b>
	<b>Test Stands</b>	<b>29</b>
	<b>Grips &amp; Attachments</b>	<b>43</b>
	<b>Accessories</b>	<b>58</b>
	<b>Dimensional Drawings</b>	<b>63</b>

## Configuring a Mark-10 System

### Force Testing Systems

#### 1 Test stand

Produces the force needed for the test. A test stand eliminates much of the variability inherent in hand-held testing with a force gauge. Motorized and manual models are available.

#### 2 Digital force gauge

Measures the force being produced on the test sample. Choose from several gauge series. All Mark-10 gauges mount to Mark-10 test stands without the need for any extra adapters.

#### 3 Test stand options

Numerous options are available to increase the functionality of test stands, including digital travel indication, PC control, cycling, extended speed ranges, and more.

#### 4 Grips and attachments

Choose from a wide range of grips and attachments, many designed for specific tests such as peel testing, wire terminal testing, and more.



### Torque Testing Systems

#### 1 Test stand

Produces the torque needed for the test. A test stand eliminates much of the variability inherent in hand-held testing with a torque gauge. Motorized and manual models are available. Basic and advanced motorized models are available.

#### 2 Torque indicator / gauge

Measures and displays the torque being produced on the test sample. Choose a force/torque indicator with Series R50 remote sensor, or the basic all-in-one TT03. Several torque capacities are available. All mount to Mark-10 torque test stands without the need for any extra adapters.

#### 3 Grips and attachments

Choose from a selection of grips and attachments, designed for such applications as bottle cap torque testing, fastener torque testing, and more.





# Digital Force & Torque Gauges



## Series 7

Series 7 professional digital force gauges are designed with a number of sophisticated features for the most demanding tension and compression measurement applications, up to 500 lbf (2,500 N). The gauges feature  $\pm 0.1\%$  accuracy and a blazingly fast, industry-leading sampling rate of 14,000 Hz, producing reliable results for extremely quick-action tests.

### Features:

- **High speed data capture and storage**  
Capture and store up to 5,000 continuous data points at a rate of up to 14,000 readings per second. This unique function is ideal for capturing switch activation forces, sharp breaks, and other short-duration applications.
- **Automatic data output / save / zero / I/O pin toggle**  
Upon peak force detection. I/O pin toggle can stop a Mark-10 motorized test stand.
- **Programmable footswitch command string**  
Up to 3 functions may be specified, along with delays between each function.
- **Custom unit**  
A user-defined unit multiplier may be programmed for custom applications.
- **1st / 2nd peak detection**  
For tensile testing and other applications.



## Series 5

Series 5 premium digital force gauges feature a fast sampling rate of 7,000 Hz and  $\pm 0.1\%$  accuracy. Additional advanced features such as averaging mode, external trigger mode, password protection, and data memory for 1,000 readings make this flexible gauge series ideal for a wide range of applications. Capacities up to 1,000 lbf [5,000 N].

### Features:

- **Communication with external devices**  
Full ASCII command set, allowing for communication with a PC, PLC, or other device through USB or RS-232. Mitutoyo and analog outputs also included.
- **Averaging / external trigger modes**  
Addresses the need to record the average force over time, useful in applications such as peel testing, while external trigger mode makes switch activation testing simple and accurate.
- **Data memory**  
1,000-point data memory with statistics (min, max, mean, standard deviation), and outputs.
- **Password protection**  
Passwords may be set for calibration and for individual keys, designed to protect the gauge against unauthorized changes.



# Digital Force & Torque Gauges



## Series 5 COF

The M5-2-COF coefficient of friction (COF) gauge is an integral part of a COF testing system, typically including a motorized test stand and COF fixture. With a capacity of 2 lbF [10 N], the gauge can be used to measure friction for a wide range of materials, ideal for conformance to ASTM D1894 and other relevant standards. Static and kinetic coefficients are displayed on the backlit LCD, and are calculated from a user-programmable sled weight.

### Features:

- **Programmable sled weight**  
The COF is calculated based on the sled weight, adjustable from 100 to 1,000 g, to conform to various standards. A password can be set to protect settings from unauthorized changes.
- **Communication with external devices**  
Full ASCII command set, allowing for communication with a PC, PLC, or other device through USB or RS-232. Mitutoyo and analog outputs also included.
- **Data memory**  
1,000-point data memory with statistics (min, max, mean, standard deviation), and outputs.
- **Password protection**  
Passwords may be set for calibration and for individual keys, designed to protect the gauge against unauthorized changes.



## Series 4

Series 4 advanced digital force gauges feature a sampling rate of 3,000 Hz and  $\pm 0.2\%$  accuracy, producing reliable, accurate results in a wide range of applications. Set point indicators with outputs are ideal for pass/fail testing, while an analog load bar provides graphical representation of applied load. Data memory for 50 readings is also provided, along with data communication capabilities.

### Features:

- **Data outputs**  
USB, RS-232, Mitutoyo, and analog outputs.
- **Data memory**  
50-point data memory with statistics (min, max, mean, standard deviation), and outputs.
- **Set point indicators with outputs**  
High, low, and in-range indicators and outputs are activated according to programmed upper and lower set points.
- **Analog load bar**  
Provides visual representation of applied load, and helps provide feedback for an imminent overload condition.



# Digital Force & Torque Gauges



## Series 3

Series 3 basic digital force gauges feature a sampling rate of 2,000 Hz and  $\pm 0.3\%$  accuracy, ideal for numerous applications in virtually every industry. Set point indicators are useful for visual pass/fail testing, while an analog load bar provides graphical representation of applied load. Ultra-compact, reversible housing allows for flexibility in many mounting configurations with space constraints.

### Features:

- **USB data output**  
Continuous or individual readings may be output to a PC through included USB output.
- **Set point indicators**  
High, low, and in-range indicators are displayed according to programmed upper and lower set points.
- **Analog load bar**  
Provides visual representation of applied load, and helps provide feedback for an imminent overload condition.
- **Ultra-compact design**  
Allows for flexibility in many mounting configurations. Reversible housing allows for hand-held use or test stand mounting.



## Series 2

Series 2 digital force gauges are designed for basic tension and compression force testing applications up to 500 lbF (2,500 N). Peak tension and compression readings are reliably captured via the gauges'  $\pm 0.5\%$  accuracy and 500 Hz sampling rate. A backlit graphic LCD displays the current, peak tension, or peak compression reading. Features an ultra-compact, reversible housing.

### Features:

- **Peak capture**  
For compression and tension measurements.
- **Selectable units of measurement**  
Select lbF, kgF, or N.
- **Battery or AC powered**  
Powered by a rechargeable battery or AC adapter.
- **Ultra-compact design**  
Allows for flexibility in many mounting configurations. Reversible housing allows for hand-held use or test stand mounting.



# Digital Force & Torque Gauges



## Series TT03

Series TT03 digital torque gauges are designed for clockwise and counter-clockwise torque testing applications in virtually every industry, with capacities from 10 ozFin to 100 lbFin (7 to 1,150 Ncm). A dedicated remote torque sensor with Jacobs chuck can be used to grip a sample, bit, or fixture. The gauges' rugged aluminum housing allows for hand-held use or test stand mounting for more sophisticated testing requirements.

### Features:

- **Rugged, compact design**  
Indicator and remote sensor with Jacobs chuck. Can be hand-held or mounted to a test stand.
- **USB data output**  
Continuous or individual readings may be output to a PC through included USB output.
- **Set point indicators**  
High, low, and in-range indicators are displayed according to programmed upper and lower set points.
- **Analog load bar**  
Provides visual representation of applied load, and helps provide feedback for an imminent overload condition.



## Series TT01

Series TT01 cap torque testers provide closure manufacturers, bottlers, and food and beverage companies an accurate and simple way to measure application and removal torques. Adjustable posts grip a broad range of container shapes and sizes, while sets of optional jaws are available as an alternative gripping methods. Peak torque readings are always shown on the large, backlit graphic display.

### Features:

- **USB, RS-232, Mitutoyo, and analog outputs**
- **Data memory**  
1,000-point data memory with statistics (min, max, mean, standard deviation), and outputs.
- **Set point indicators with outputs**  
Convenient for pass/fail testing.
- **Automatic data output / save / zero**  
Upon peak torque detection.
- **1st / 2nd peak detection**  
For slip and breakaway torques in tamper-evident closures.



# Digital Force & Torque Gauges



## Series TT05

Series TT05 universal torque testers can be used for a range of applications up to 100 lbFin [11.5 Nm]. The stainless steel loading surface features a matrix of threaded holes, ideal for accommodating specialized fixtures and attachments. The testers' rugged design and simple, intuitive operation allow for use in laboratory and production environments. Technical specifications and functionality are the same as with Series TT01.

### Features:

- **Stainless steel loading plate with threaded holes**  
Accommodates specialized fixtures and attachments.
- **USB, RS-232, Mitutoyo, and analog outputs**
- **Data memory**  
1,000-point data memory with statistics (min, max, mean, standard deviation), and outputs.
- **Set point indicators with outputs**  
Convenient for pass/fail testing.
- **Automatic data output / save / zero**  
Upon peak torque detection.



## Series TT02

Series TT02 Torque Tool Testers present a simple yet accurate solution for testing torque screwdrivers, wrenches, and other tools. The TT02 features a solid aluminum housing, making it rugged enough for many years of service in production or laboratory use, while a universal receptacle with square drive and grooves accepts common bits and attachments. 1st / 2nd peak detection is provided for click-type tools.

### Features:

- **USB, RS-232, Mitutoyo, and analog outputs**
- **Data memory**  
1,000-point data memory with statistics (min, max, mean, standard deviation), and outputs.
- **Set point indicators with outputs**  
Convenient for pass/fail testing.
- **Automatic data output / save / zero**  
Upon peak torque detection.
- **1st / 2nd peak detection**  
For slip and breakaway torques in tamper-evident closures.



# Digital Force & Torque Gauges

## Specifications - Force Gauges

	Series 7 Professional	Series 5 Advanced	Series 4 Performance
Accuracy (% of full scale)	±0.1%		±0.2%
Sampling rate	14,000 Hz	7,000 Hz	3,000 Hz
Resolution	1/5,000		1/2,000
Outputs	USB, RS-232, Mitutoyo, Analog		
RS-232	Configurable up to 115,200 baud		
Mitutoyo (Digimatic)	Serial BCD suitable for all Mitutoyo SPC-compatible devices		
Analog	±1 VDC, ±0.25% FS at capacity. Positive for compression, negative for tension		
General purpose I/O	Three open drain outputs, one input		
Set point	Three open drain lines		
MESUR™ Lite software included	Yes		
Data output functionality	Automatic output or by pressing DATA button, or requesting from a PC or other device.		By pressing DATA button, or requesting from a PC or other device (currently displayed reading only).
ASCII command set for external control	Full command set		"?" only (request current reading)
Communication w/MESUR™ gauge and MESUR™ Lite	Full communication		Single point or continuous data output only
Communication with ESM301 test stand and Series DC controllers	Full communication, including PC control		Stop at force set points, overload protection, and communication through "?" character only
Data memory	5,000 readings, with output	1,000 readings, with output	50 readings, with output
Data memory deletion	Any individual data point, or clear all		
Statistic calculations and output to PC	Max, min, mean, std. dev., number of readings, with output		
Break Detection	Yes*	No	
1st / 2nd Peak Detection	Yes*	No	
Programmable footswitch command string	Yes	No	
Averaging mode	Yes*	Yes	No
External trigger mode	Yes**	Yes	No
Analog load bar graph shown on display	Yes		
Set points (for pass / fail indication)	Yes with high / low indicators, markers on analog bar graph, and outputs		
Password Protection	Yes, for calibration and individual keys		No
Peak readings always displayed	Yes		
Programmable audible tones	Yes		
Calibration procedure	Configurable number of data points (up to 10 in each direction)		
Overload outputs	Dedicated pins for tension and compression		
Battery life	Rechargeable. Backlight on: up to 7 hours of continuous use / Backlight off: up to 24 hours of continuous use		
Units of measurement	lbF, ozF, gF, kgF, N, kN, mN (depending on model)		
Safe overload	150% of full scale (display shows warning at 110% and above)		
Weight (lb [kg])	M7-012 - M7-100: 1.0 [0.45] M7-200 - M7-500: 1.2 [0.54]	M5-012 - M5-100: 1.0 [0.45] M5-200 - M5-500: 1.2 [0.54] M5-1000 - M5-2000: 1.8 [0.82]	M4-012 - M4-100: 1.0 [0.45] M4-200 - M4-500: 1.2 [0.54]
Included items	Carrying case, chisel, cone, V-groove, hook, flat, extension rod, universal voltage AC adapter/charger, rechargeable battery, quick-start guide, USB cable, resource CD (USB driver, MESUR Lite software, MESURgauge DEMO software, and user's guide), NIST-traceable certificate of calibration with data		

\* With configurable automatic data output, data storage, and zero function upon event completion. Can also stop travel of certain motorized test stands.

\*\* Can stop certain motorized test stands upon event completion.



# Digital Force & Torque Gauges



Series 3 Basic		Series 2 Economical		
±0.3%		±0.5%		Accuracy (% of full scale)
2,000 Hz		500 Hz		Sampling rate
	1/1,000			Resolution
USB		No		Outputs
No		N/A		RS-232
Configurable up to 115,200 baud		N/A		USB
No		N/A		Mitutoyo (Digimatic)
No		N/A		Analog
No		N/A		General purpose I/O
No		N/A		Set point
Yes		N/A		MESUR™ Lite software included
By pressing DATA button, or requesting from a PC or other device (currently displayed reading only)		N/A		Data output functionality
"?" only (request current reading)		N/A		ASCII command set for external control
Single point or continuous data output only		N/A		Communication w/MESUR™ gauge and MESUR™ Lite
No		N/A		Communication with ESM301 test stand and Series DC controllers
	No			Data memory
	N/A			Data memory deletion
	N/A			Statistic calculations and output to PC
	No			Break Detection
	No			1st / 2nd Peak Detection
	No			Programmable footswitch command string
No		N/A		Averaging mode
No		No		External trigger mode
Yes		No		Analog load bar graph shown on display
Yes with high/low indicators, markers on analog bar graph, no output		No		Set points (for pass / fail indication)
	No			Password Protection
Yes		No (Peak mode must be selected)		Peak readings always displayed
Yes		No		Programmable audible tones
	Configurable number of data points (up to 10 in each direction)			Calibration procedure
	No		N/A	Overload outputs
	Rechargeable. Backlight on: up to 7 hours of continuous use / Backlight off: up to 24 hours of continuous use			Battery life
	lbf, gF, kgF, N (depending on model)		lbf, kgF, N	Units of measurement
	150% of full scale (display shows warning at 110% and above)			Safe overload
	M3-012 - M3-100: 0.7 [0.33] M3-200 - M3-500: 0.9 [0.41]		M2-2 - M2-100: 0.7 [0.33] M2-200 - M2-500: 0.9 [0.41]	Weight (lb [kg])
Carrying case, chisel, cone, V-groove, hook, flat, extension rod, universal voltage AC adapter/charger, rechargeable battery, quick-start guide, USB cable, resource CD (USB driver, MESUR Lite software, MESURgauge DEMO software, and user's guide), NIST-traceable certificate of calibration without data.		Rechargeable battery, quick-start guide, resource CD, certificate of conformance		Included items



# Digital Force & Torque Gauges

## Specifications - Torque Gauges and Indicators



	TT01	TT05	TT02	TT03
Accuracy (% of full scale)	±0.3%	±0.3%	±0.3%	±0.5%
Password protection		Yes		No
Sampling rate	7,000 Hz			2,000 Hz
Resolution	1/1,000			
Outputs	USB, RS-232 Mitutoyo, Analog			USB
USB / RS-232	Configurable up to 115,200 baud			
Mitutoyo (Digimatic)	Serial BCD suitable for all Mitutoyo SPC-compatible devices			N/A
Analog	±1 VDC, ±0.25% FS. + for compression / CW, - for tension / CCW			N/A
General purpose I/O	Three open drain outputs, one input			N/A
Set point	Yes, three open drain lines			No
MESUR™ Lite software included	Yes			
Communication with MESUR™ gauge and MESUR™ Lite software	Single point or continuous data, send from gauge or request from software			
Data memory	1,000 readings, with output			No
Data memory deletion	Individual data points, or clear all			N/A
Statistics calculations	Max, min, mean, std. dev., number of readings, with output			N/A
Analog load bar graph shown on display	Yes			
Keypad password protection	Yes, for calibration and keys			No
Peak readings calculated	Yes			
Break detection*		Yes		No
1st / 2nd peak detection*		Yes		No
Programmable audible tones	Yes			
No. of units of measurement	5			3
Battery life (with backlight on/off)	Backlight on: up to 7 hours of continuous use, Backlight off: up to 24 hours of continuous use			
Safe overload	150% of full scale (display shows "OVER" at 110% and above)			
Weight (lb [kg])	8.4 [3.8]	10.9 [4.9]	5.8 [2.6]	1.8 [0.8]
Included items	1/4" hex to 3/8" square adapter (TT02 Only), Carrying Case (TT03 only) Universal voltage AC adapter, battery, quick-start guide, resource CD (USB driver, MESUR™ Lite software, MESUR™ gauge DEMO software, and user's guide), and certificate of calibration.			

\* With configurable automatic data output, data storage, and zero function upon detection of peak value(s).

# Digital Force & Torque Gauges



## Ordering Information - Force Gauges

Model No.	Capacity x Resolution							
	lbF	ozF	kgF	gF	N	kN	mN	
M7	M7-012	0.12 x 0.00002	2 x 0.0005	-	50 x 0.01	0.5 x 0.0001	-	500 x 0.1
	M7-025	0.25 x 0.00005	4 x 0.001	-	100 x 0.02	1 x 0.0002	-	1,000 x 0.2
	M7-05	0.5 x 0.0001	8 x 0.002	-	250 x 0.05	2.5 x 0.0005	-	2,500 x 0.5
	M7-2	2 x 0.0005	32 x 0.01	1 x 0.0002	1,000 x 0.2	10 x 0.002	-	-
	M7-5	5 x 0.001	80 x 0.02	2.5 x 0.0005	2,500 x 0.5	25 x 0.005	-	-
	M7-10	10 x 0.002	160 x 0.05	5 x 0.001	5,000 x 1	50 x 0.01	-	-
	M7-20	20 x 0.005	320 x 0.1	10 x 0.002	10,000 x 2	100 x 0.02	-	-
	M7-50	50 x 0.01	800 x 0.2	25 x 0.005	25,000 x 5	250 x 0.05	-	-
	M7-100	100 x 0.02	1,600 x 0.5	50 x 0.01	50,000 x 10	500 x 0.1	-	-
	M7-200	200 x 0.05	3,200 x 1	100 x 0.02	-	1,000 x 0.2	1 x 0.0002	-
	M7-500	500 x 0.1	8,000 x 2	250 x 0.05	-	2,500 x 0.5	2.5 x 0.0005	-
M5	M5-012	0.12 x 0.00002	2 x 0.0005	-	50 x 0.01	0.5 x 0.0001	-	500 x 0.1
	M5-025	0.25 x 0.00005	4 x 0.001	-	100 x 0.02	1 x 0.0002	-	1,000 x 0.2
	M5-05	0.5 x 0.0001	8 x 0.002	-	250 x 0.05	2.5 x 0.0005	-	2,500 x 0.5
	M5-2	2 x 0.0005	32 x 0.01	1 x 0.0002	1,000 x 0.2	10 x 0.002	-	-
	M5-5	5 x 0.001	80 x 0.02	2.5 x 0.0005	2,500 x 0.5	25 x 0.005	-	-
	M5-10	10 x 0.002	160 x 0.05	5 x 0.001	5,000 x 1	50 x 0.01	-	-
	M5-20	20 x 0.005	320 x 0.1	10 x 0.002	10,000 x 2	100 x 0.02	-	-
	M5-50	50 x 0.01	800 x 0.2	25 x 0.005	25,000 x 5	250 x 0.05	-	-
	M5-100	100 x 0.02	1,600 x 0.5	50 x 0.01	50,000 x 10	500 x 0.1	-	-
	M5-200	200 x 0.05	3,200 x 1	100 x 0.02	-	1,000 x 0.2	1 x 0.0002	-
	M5-500	500 x 0.1	8,000 x 2	250 x 0.05	-	2,500 x 0.5	2.5 x 0.0005	-
	M5-1000	1,000 x 0.5	1,600 x 5	500 x 0.2	-	5,000 x 2	5 x 0.002	-
M5-2000	2,000 x 1	32,000 x 20	1,000 x 0.5	-	10,000 x 5	10 x 0.005	-	
M4	M4-012	0.12 x 0.00005	2 x 0.001	-	50 x 0.02	0.5 x 0.0002	-	500 x 0.2
	M4-025	0.25 x 0.0001	4 x 0.002	-	100 x 0.05	1 x 0.0005	-	1,000 x 0.5
	M4-05	0.5 x 0.0002	8 x 0.005	-	250 x 0.1	2.5 x 0.001	-	2,500 x 1
	M4-2	2 x 0.001	32 x 0.02	1 x 0.0005	1,000 x 0.5	10 x 0.005	-	-
	M4-5	5 x 0.002	80 x 0.05	2.5 x 0.001	2,500 x 1	25 x 0.01	-	-
	M4-10	10 x 0.005	160 x 0.1	5 x 0.002	5,000 x 2	50 x 0.02	-	-
	M4-20	20 x 0.01	320 x 0.2	10 x 0.005	10,000 x 5	100 x 0.05	-	-
	M4-50	50 x 0.02	800 x 0.5	25 x 0.01	25,000 x 10	250 x 0.1	-	-
	M4-100	100 x 0.05	1,600 x 1	50 x 0.02	50,000 x 20	500 x 0.2	-	-
	M4-200	200 x 0.1	3,200 x 2	100 x 0.05	-	1,000 x 0.5	1 x 0.0005	-
	M4-500	500 x 0.2	8,000 x 5	250 x 0.1	-	2,500 x 1	2.5 x 0.001	-



All models include 110V AC adapters

Add suffix 'E' for euro plug (220V), 'U' for UK plug (220V) or 'A' for Australian plug (220V)

Example: M7-05E, M5-100U, M4-500A





# Digital Force & Torque Gauges

## Capacity x Resolution - Force Gauges

Model No.	Capacity x Resolution				
	lbF	kgF	gF	N	
M3	M3-012	0.12 x 0.0001	-	50 x 0.05	0.5 x 0.0005
	M3-025	0.25 x 0.0002	-	100 x 0.1	1 x 0.001
	M3-05	0.5 x 0.0005	-	250 x 0.2	2.5 x 0.002
	M3-2	2 x 0.002	1 x 0.001	-	10 x 0.01
	M3-5	5 x 0.005	2.5 x 0.002	-	25 x 0.02
	M3-10	10 x 0.01	5 x 0.005	-	50 x 0.05
	M3-20	20 x 0.02	10 x 0.01	-	100 x 0.1
	M3-50	50 x 0.05	25 x 0.02	-	250 x 0.2
	M3-100	100 x 0.1	50 x 0.05	-	500 x 0.5
	M3-200	200 x 0.2	100 x 0.1	-	1,000 x 1
	M3-500	500 x 0.5	250 x 0.2	-	2,500 x 2
M2	M2-2	2 x 0.002	1 x 0.001	-	10 x 0.01
	M2-5	5 x 0.005	2.5 x 0.002	-	25 x 0.02
	M2-10	10 x 0.01	5 x 0.005	-	50 x 0.05
	M2-20	20 x 0.02	10 x 0.01	-	100 x 0.1
	M2-50	50 x 0.05	25 x 0.02	-	250 x 0.2
	M2-100	100 x 0.1	50 x 0.05	-	500 x 0.5
	M2-200	200 x 0.2	100 x 0.1	-	1000 x 1
	M2-500	500 x 0.5	250 x 0.2	-	2500 x 2



All models include 110V AC adapters

Add suffix 'E' for euro plug (220V), 'U' for UK plug (220V) or 'A' for Australian plug (220V)

Example: M3-05E, M3-20U, M2-100A

# Digital Force & Torque Gauges



## Capacity x Resolution - Torque Gauges

Model No.		Capacity x Resolution					
		ozFin	lbFin	kgFcm	kgFmm	Ncm	Nm
TT01	MTT01-12	192 x 0.1	12 x 0.005	14 x 0.01	-	135 x 0.1	1.35 x 0.001
	MTT01-25	400 x 0.2	25 x 0.01	28 x 0.02	-	290 x 0.2	2.9 x 0.002
	MTT01-50	800 x 0.5	50 x 0.02	58 x 0.05	-	570 x 0.5	5.7 x 0.005
	MTT01-100	1,600 x 1	100 x 0.05	116 x 0.1	-	1,150 x 1	11.5 x 0.01
	CT001	Optional sample gripping jaws, pair					
	CT002	Optional carrying case for TT01					
	CT003	Optional adjustable sample gripping jaws, pair					
TT05	MTT05-12	192 x 0.1	12 x 0.005	14 x 0.01	-	135 x 0.1	1.35 x 0.001
	MTT05-25	400 x 0.2	25 x 0.01	28 x 0.02	-	290 x 0.2	2.9 x 0.002
	MTT05-50	800 x 0.5	50 x 0.02	58 x 0.05	-	570 x 0.5	5.7 x 0.005
	MTT05-100	1,600 x 1	100 x 0.05	58 x 0.05	-	1,150 x 1	11.5 x 0.01
TT02	MTT02-12	192 x 0.1	12 x 0.005	14 x 0.01	-	135 x 0.1	1.35 x 0.001
	MTT02-25	400 x 0.2	25 x 0.01	28 x 0.02	-	290 x 0.2	2.9 x 0.002
	MTT02-50	800 x 0.5	50 x 0.02	58 x 0.05	-	570 x 0.5	5.7 x 0.005
	MTT02-100	1,600 x 1	100 x 0.05	116 x 0.1	-	1,150 x 1	11.5 x 0.01
	ST001	Optional bench mounting bracket for TT02					
	ST002	Optional carrying case for TT02					
TT03	MTT03-10Z	10 x 0.01	-	-	7 x 0.005	7 x 0.005	-
	MTT03-20Z	20 x 0.02	-	-	14 x 0.01	14 x 0.01	-
	MTT03-50Z	50 x 0.05	-	-	36 x 0.05	36 x 0.05	-
	MTT03-12	192 x 0.2	12 x 0.01	-	-	135 x 0.1	-
	MTT03-50	800 x 1	50 x 0.05	-	-	570 x 0.5	-
	MTT03-100	1600 x 2	100 x 0.1	-	-	1,150 x 1	-

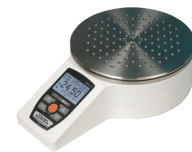

All models include 110V AC adapters

Add suffix 'E' for euro plug (220V), 'U' for UK plug (220V) or 'A' for Australian plug (220V)

Example: MTT01-50E, MTT02-100U, MTT03-50ZA



# Plug & Test™ Indicators & Sensors

## Measure force and torque with interchangeable indicators and remote sensors

Models 7i, 5i, and 3i force / torque indicators are designed for use with Mark-10's Plug & Test™ remote force and torque sensors. All calibration and configuration data is saved within the sensors' smart connectors - not the indicator - allowing for true interchangeability. Each sensor series is available in a range of capacities, from 0.25 to 10,000 lbF (1 N to 50 kN) full scale and from 10 ozFin to 5,000 lbFin (7 Ncm to 550 Nm) full scale. Sensor details are provided on the following pages.







## Torque Sensors

### 1 Series R50

#### Universal torque sensors, fixed chuck

Measure bidirectional torque for a wide variety of applications. Contain a chuck for up to 1/2" diameter samples. Sensors can be used as hand held devices, or mounted to a torque test stand. Capacities available from 10 ozFin to 100 lbFin [7 to 1,150 Ncm].

### 2 Series R51

#### Universal torque sensors, interchangeable chucks

A great solution for general bidirectional torque testing applications with several different sample sizes. Three interchangeable chuck capacities and bit holder are available. The R51 has super overload protection and is available in capacities from 10 ozFin to 100 lbFin [7 to 1,150 Ncm].

### 3 Series R55

#### Wrench extension torque sensors

Convert any wrench to a torque tool with this sensor series, or use it as a component of a torque testing system. Capacities available from 20 to 5,000 lbFin [220 Ncm to 550 Nm].

### 4 Series R52

#### Static torque sensors

Calibrate torque tools with these sensors, or use them as components of a torque testing system. Tapped holes on every surface allow for easy mounting to a work bench or fixture. Capacities available from 10 ozFin to 100 lbFin [7 to 1,150 Ncm].

### 5 Series R53

#### Closure torque sensors

Ideal for testing torque on bottle caps, closures, valves, fasteners, and other items in sizes ranging from 0.56 to 5.7 in [14 to 148 mm] diameter. Models contain reversible jaws or movable posts to easily accommodate a variety of shapes and sizes. Capacities available from 10 ozFin to 100 lbFin [7 to 1,150 Ncm].

## Force Sensors

### 6 Series R01

#### Tension / compression sensors

A rugged sensor series for measuring tensile and compressive force of up to 10,000 lbF [50 kN]. Durable S-beam design with thread on two sides allows for many applications and setups. Solid steel construction ensures many years of use.

### 7 Series R03

#### Inline tension / compression sensors

Measure tensile and compressive loads for a wide variety of applications, available in capacities from 0.25 lbF to 100 lbF [1 to 500 N]. Thread on two sides can accept a variety of hooks and implements, making this sensor series particularly well suited for inline tests.

### 8 Series R04

#### Miniature tension / compression sensors

Extremely compact force measurement sensors for tensile and compressive loads in applications with limited space. Capacities available from 0.25 lbF to 100 lbF. [1 to 500 N] The sensors include threaded holes on two sides for the mounting of attachments or implements.

### 9 Series R02

#### Compact compression sensors

Button type sensors for compressive loads of up to 10,000 lbF [50 kN]. Compact and rugged, the R02 is ideal for heavy duty applications with space constraints.

### 10 Series R05

#### Pull / tension sensor

Fully enclosed force sensor for tension and compression testing. Useful in ergonomics testing, workplace safety testing, and general lifting or push/pull requirements. For up to 500 lbF [2,500 N] of force.



# Plug & Test™ Adapter Model PTA

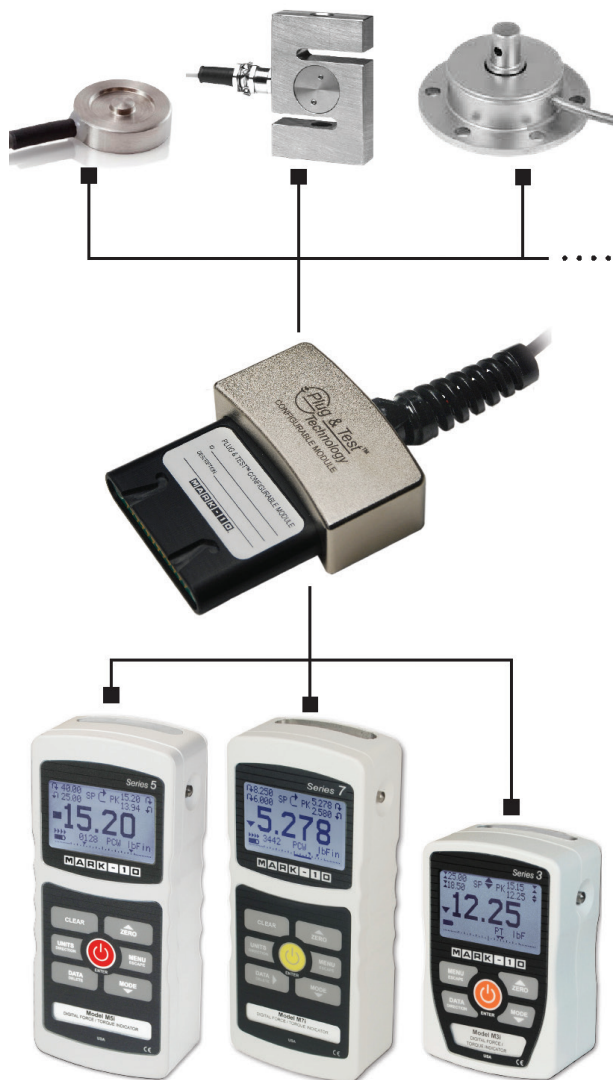

## Model PTA

Connect common strain gage-based load cells, force sensors, and torque sensors to Models 7i, 5i and 3i indicators with this user-configurable adapter and software.

Sensor capacity and resolutions may be programmed via an included software utility, which includes a library of common force capacities from 0.12 to 750,000 lbF (0.5 N to 4,000 kN), and torque capacities from 10 ozF in to 40,000 lbF ft (7 Ncm to 57,000 Nm).

An identification number may be programmed, which is displayed upon indicator power-up or the indicator's Information screen. Through Plug & Test™ technology, all configuration and calibration information is saved within the adapter. This flexibility allows for interchangeability between multiple sensors with any Mark-10 indicator.

## Features:

- Compatible with strain gage-based load cells, force sensors, and torque sensors
- Screw terminal block allows for easy connection of sensor wires
- Software configuration utility is included, for easy programming of sensor capacity, resolution, and identification number
- Program the adapter via USB or RS-232 through the indicator
- Mounting holes for bench mounting

## Sensor Requirements:

Type: Full bridge  
Resistance: 300 - 1,000 ohms  
Sensitivity: 1-3 mV/V

## Ordering Information

Model No.	Description
PTA	Plug and Test™ adapter

# Plug & Test™ Indicators & Sensors



## Specifications - Force and Torque Indicators



**Model 7i**  
Professional



**Model 5i**  
Advanced



**Model 3i**  
Basic

Accuracy (% of full scale)	±0.1 + sensor		±0.2% + sensor
Sensor password protection	Yes		No
Sampling rate	14,000 Hz	7,000 Hz	2,000 Hz
Resolution	1/2,000 or 1/1,000, depending on sensor		1/1,000
Outputs	USB, RS-232, Mitutoyo, Analog		USB
RS-232	Configurable up to 115,200 baud		No
USB	Configurable up to 115,200 baud		
Mitutoyo (Digimatic)	Serial BCD suitable for all Mitutoyo SPC-compatible devices		No
Analog	±1 VDC, ±2% FS. + for compression / CW, - for tension / CCW		No
General purpose I/O	Three open drain outputs, one input		No
Set point	Three open drain lines		No
MESUR™ Lite software included	Yes		
Data output functionality	Automatic output or by pressing DATA button, or requesting from a PC or other device		By pressing DATA button, or requesting from a PC or other device (currently displayed reading only)
ASCII command set for external control	Full command set		"?" only (request current reading)
Communication with MESUR™ gauge and MESUR™ Lite software	Full communication		Send single reading from gauge only, cannot request from software
Communication with ESM301 test stand and Series DC test stand controllers	Full communication, including PC control		No
Data memory	5,000 readings, with output	1,000 readings, with output	No
Data memory deletion	Individual data points, or clear all		N/A
Statistics calculations and output to PC	Max, min, mean, std. dev., number of readings, with output		No
Break detection	Yes*		No
1st / 2nd peak detection	Yes*		No
Programmable footswitch command string	Yes*		No
Averaging mode	Yes*	Yes	No
External trigger mode	Yes**	Yes	No
Analog load bar graph shown on display	Yes		
Set points (for pass/fail indication)	Yes, with high/low indicators		
Keypad password protection	Yes, for calibration and keys		No
Peak readings always displayed	Yes		
Programmable audible tones	Yes		
Calibration procedure	Configurable number of data points (up to 10 in each direction)		
Overload outputs	Dedicated pins for tension and compression		No
No. of units of measurement	5		3
Battery life (with backlight on/off)	Up to 7 hours of continuous use / Up to 24 hours of continuous use		
Weight	0.7 lb [0.3 kg]		
Included items	Carrying case, universal voltage AC adapter, battery, quick-start guide, USB cable, resource CD (USB driver, MESUR™ Lite software, MESUR™ gauge DEMO software, and user's guide), and certificate of conformance.		

\* With configurable automatic data output, data storage, and zero function upon event completion. Can also stop travel of certain motorized test stands.

\*\* Can stop travel of certain motorized test stands upon event completion.



# Plug & Test™ Indicators & Sensors

## Specifications

Model No.	Description
M71	Professional force / torque indicator, 110V
M51	Advanced force / torque indicator, 110V
M31	Basic force / torque indicator, 110V

All models include 110V AC adapters. Add suffix 'E' for euro plug (220V), 'U' for UK plug (220V), or 'A' for Australian plug (220V).

Example: M5-50E, M5-200U, M5-1000A

Model No.	Capacity x Resolution - with Model 7i & 5i indicators						Capacity x Resolution - with Model 3i indicator				Accuracy* (±% FS)	Safe Overload	
	lbF	ozF	gF	kgF	N	kN	lbF	kgF	N	kN			
R01**	MR01-50	50 x 0.02	800 x 0.5	25,000 x 10	25 x 0.01	250 x 0.1	-	50 x 0.05	25 x 0.02	250 x 0.2	-	0.15%	150%
	MR01-100	100 x 0.05	1,600 x 1	50,000 x 20	50 x 0.02	500 x 0.2	-	100 x 0.1	50 x 0.05	500 x 0.5	-		
	MR01-200	200 x 0.1	3,200 x 2	-	100 x 0.05	1,000 x 0.5	1 x 0.0005	200 x 0.2	100 x 0.1	1,000 x 1	-		
	MR01-500	500 x 0.2	8,000 x 5	-	250 x 0.1	2,500 x 1	2.5 x 0.001	500 x 0.5	250 x 0.2	2,500 x 2	-		
	MR01-1000	1,000 x 0.5	16,000 x 10	-	500 x 0.2	5,000 x 2	5 x 0.002	1,000 x 1	500 x 0.5	5,000 x 5	-		
	MR01-2000	2,000 x 1	32,000 x 20	-	1,000 x 0.5	10,000 x 5	10 x 0.005	2,000 x 2	1,000 x 1	10,000 x 10	-		
	MR01-5000	5,000 x 2	-	-	2,500 x 1	25,000 x 10	25 x 0.01	5,000 x 5	2,500 x 2	-	25 x 0.02		
MR01-10000	10,000 x 5	-	-	5,000 x 2	50,000 x 25	50 x 0.02	10,000 x 10	5,000 x 5	-	50 x 0.05			
R02	MR02-100	100 x 0.05	1,600 x 1	50,000 x 20	50 x 0.02	500 x 0.2	-	100 x 0.1	50 x 0.05	500 x 0.5	-	0.5%	150%
	MR02-200	200 x 0.1	3,200 x 2	-	100 x 0.05	1,000 x 0.5	1 x 0.0005	200 x 0.2	100 x 0.1	1,000 x 1	-		
	MR02-500	500 x 0.2	8,000 x 5	-	250 x 0.1	2,500 x 1	2.5 x 0.001	500 x 0.5	250 x 0.2	2,500 x 2	-		
	MR02-1000	1,000 x 0.5	16,000 x 10	-	500 x 0.2	5,000 x 2	5 x 0.002	1,000 x 1	500 x 0.5	5,000 x 5	-		
	MR02-2000	2,000 x 1	32,000 x 20	-	1,000 x 0.5	10,000 x 5	10 x 0.005	2,000 x 2	1,000 x 1	10,000 x 10	-		
	MR02-5000	5,000 x 2	-	-	2,500 x 1	25,000 x 10	25 x 0.01	5,000 x 5	2,500 x 2	-	25 x 0.02		
	MR02-10000	10,000 x 5	-	-	5,000 x 2	50,000 x 25	50 x 0.02	10,000 x 10	5,000 x 5	-	50 x 0.05		
R03**	MR03-025	0.25 x 0.0001	4 x 0.002	100 x 0.05	-	1 x 0.0005	1,000 x 0.5 mN	0.25 x 0.0002	100 x 0.1 gF	1 x 0.001	-	0.15%	150%
	MR03-05	0.5 x 0.0002	8 x 0.005	250 x 0.1	-	2.5 x 0.001	2,500 x 1 mN	0.5 x 0.0005	250 x 0.2 gF	2.5 x 0.002	-		
	MR03-2	2 x 0.001	32 x 0.02	1,000 x 0.5	1 x 0.0005	10 x 0.005	-	2 x 0.002	1 x 0.001	10 x 0.01	-	0.15%	150%
	MR03-5	5 x 0.002	80 x 0.05	2,500 x 1	2.5 x 0.001	25 x 0.01	-	5 x 0.005	2.5 x 0.002	25 x 0.02	-		
	MR03-10	10 x 0.005	160 x 0.1	5,000 x 2	5 x 0.002	50 x 0.02	-	10 x 0.01	5 x 0.005	50 x 0.05	-		
	MR03-20	20 x 0.01	320 x 0.2	10,000 x 5	10 x 0.005	100 x 0.05	-	20 x 0.02	10 x 0.01	100 x 0.1	-		
	MR03-50	50 x 0.02	800 x 0.5	25,000 x 10	25 x 0.01	250 x 0.1	-	50 x 0.05	25 x 0.02	250 x 0.2	-		
	MR03-100	100 x 0.05	1,600 x 1	50,000 x 20	50 x 0.02	500 x 0.2	-	100 x 0.1	50 x 0.05	500 x 0.5	-		
R04	MR04-025	0.25 x 0.0001	4 x 0.002	100 x 0.05	-	1 x 0.0005	1,000 x 0.5 mN	0.25 x 0.0002	100 x 0.1 gF	1 x 0.001	-	0.2%	200%
	MR04-05	0.5 x 0.0002	8 x 0.005	250 x 0.1	-	2.5 x 0.001	2,500 x 1 mN	0.5 x 0.0005	250 x 0.2 gF	2.5 x 0.002	-		
	MR04-2	2 x 0.001	32 x 0.02	1,000 x 0.5	1 x 0.0005	10 x 0.005	-	2 x 0.002	1 x 0.001	10 x 0.01	-		
	MR04-5	5 x 0.002	80 x 0.05	1,000 x 0.5	2.5 x 0.001	25 x 0.01	-	5 x 0.005	2.5 x 0.002	25 x 0.02	-		
	MR04-10	10 x 0.005	160 x 0.1	5,000 x 2	5 x 0.002	50 x 0.02	-	10 x 0.01	5 x 0.005	50 x 0.05	-		
	MR04-20	20 x 0.01	320 x 0.2	10,000 x 5	10 x 0.005	100 x 0.05	-	20 x 0.02	10 x 0.01	100 x 0.1	-		
	MR04-50	50 x 0.02	800 x 0.5	25,000 x 10	25 x 0.01	250 x 0.1	-	50 x 0.05	25 x 0.02	250 x 0.2	-		
	MR04-100	100 x 0.05	1,600 x 1	50,000 x 20	50 x 0.02	500 x 0.2	-	100 x 0.1	50 x 0.05	500 x 0.5	-		
R05	MR05-500	500 x 0.2	8,000 x 5	-	250 x 0.1	2,500 x 1	2.5 x 0.001	500 x 0.5	250 x 0.2	2,500 x 2	-	0.15%	150%

All sensors include a Plug & Test™ connector for interfacing directly with a 7i, 5i or 3i indicator. NIST-traceable certificate of calibration with data is also included.

\* Accuracy refers to the sensor only. Total accuracy includes the indicator's accuracy (±0.1% or ±0.2%). For example, the total accuracy of the MR01-100 sensor with 3i indicator equals ±0.15% + ±0.2% = ±0.35% FS.

\*\* Add suffix "-1" for shortened cable, for use on the ESM1500LC, ESM303, and ESM303H test stands. Ex: MR01-1000-1. Test stand mounting hardware is included.



# Plug & Test™ Indicators & Sensors



Model No.	Capacity x Resolution with Model 7i & 5i indicators								Capacity x Resolution with Model 3i indicator				Accuracy* (±% FS)	Safe Overload			
	ozFin	lbFin	lbFft	gFcm	kgFmm	Nmm	Ncm	Nm	ozFin	lbFin	kgFmm	Ncm					
R50	MR50-10Z	10 x 0.005	-	-	700 x 0.5	7 x 0.005	70 x 0.05	7 x 0.005	-	10 x 0.01	-	7 x 0.005	7 x 0.005	0.35%	300%		
	MR50-20Z	20 x 0.01	-	-	1,400 x 1	14 x 0.01	140 x 0.1	14 x 0.01	-	20 x 0.02	-	14 x 0.01	14 x 0.01				
	MR50-50Z	50 x 0.02	-	-	3,600 x 2	36 x 0.02	350 x 0.2	35 x 0.02	-	50 x 0.05	-	36 x 0.05	35 x 0.05				
	MR50-12	192 x 0.1	12 x 0.005	1 x 0.0005	-	-	-	135 x 0.1	1.35 x 0.001	192 x 0.2	12 x 0.01	-	135 x 0.1				
	MR50-50	800 x 0.5	50 x 0.02	4 x 0.002	-	-	-	570 x 0.5	5.7 x 0.005	800 x 1	50 x 0.05	-	570 x 0.5				
	MR50-100	1,600 x 1	100 x 0.05	8 x 0.005	-	-	-	1,150 x 1	11.5 x 0.01	1,600 x 2	100 x 0.1	-	1,150 x 1				
R51	MR51-10Z	10 x 0.005	-	-	700 x 0.5	7 x 0.005	70 x 0.05	7 x 0.005	-	10 x 0.01	-	7 x 0.005	7 x 0.005	0.15%	300%		
	MR51-20Z	20 x 0.01	-	-	1,400 x 1	14 x 0.01	140 x 0.1	14 x 0.01	-	20 x 0.02	-	14 x 0.01	14 x 0.01				
	MR51-50Z	50 x 0.02	-	-	3,600 x 2	36 x 0.02	350 x 0.2	35 x 0.02	-	50 x 0.05	-	36 x 0.05	35 x 0.05				
	MR51-12	192 x 0.1	12 x 0.005	1 x 0.0005	-	-	-	135 x 0.1	1.35 x 0.001	192 x 0.2	12 x 0.01	-	135 x 0.1				
	MR51-50	800 x 0.5	50 x 0.02	4 x 0.002	-	-	-	570 x 0.5	5.7 x 0.005	800 x 1	50 x 0.05	-	570 x 0.5				
	MR51-100	1,600 x 1	100 x 0.05	8 x 0.005	-	-	-	1,150 x 1	11.5 x 0.01	1,600 x 2	100 x 0.1	-	1,150 x 1				
	G1016-1	Jacobs chuck for R51, 0.028"-0.25" [0.7 - 6.3 mm]															
	G1016-2	Jacobs chuck for R51, 0.062"-0.375" [1.6 - 9.5 mm]															
	G1016-3	Jacobs chuck for R51, 0.078"-0.5" [2.0 - 12.7 mm]															
	G1017	Bit holder for R51, 1/4" hex															
R52	MR52-10Z	10 x 0.005	-	-	700 x 0.5	7 x 0.005	70 x 0.05	7 x 0.005	-	10 x 0.01	-	7 x 0.005	7 x 0.005	0.35%	300%		
	MR52-20Z	20 x 0.01	-	-	1,400 x 1	14 x 0.01	140 x 0.1	14 x 0.01	-	20 x 0.02	-	14 x 0.01	14 x 0.01				
	MR52-50Z	50 x 0.02	-	-	3,600 x 2	36 x 0.02	350 x 0.2	35 x 0.02	-	50 x 0.05	-	36 x 0.05	35 x 0.05				
	MR52-12	192 x 0.1	12 x 0.005	1 x 0.0005	-	-	-	135 x 0.1	1.35 x 0.001	192 x 0.2	12 x 0.01	-	135 x 0.1				
	MR52-50	800 x 0.5	50 x 0.02	4 x 0.002	-	-	-	570 x 0.5	5.7 x 0.005	800 x 1	50 x 0.05	-	570 x 0.5				
	MR52-100	1,600 x 1	100 x 0.05	8 x 0.005	-	-	-	1,150 x 1	11.5 x 0.01	1,600 x 2	100 x 0.1	-	1,150 x 1				
R53	MR53-10Z	10 x 0.01	-	-	700 x 0.5	7 x 0.005	70 x 0.05	7 x 0.005	-	10 x 0.01	-	7 x 0.005	7 x 0.005	0.5%	300%		
	MR53-20Z	20 x 0.02	-	-	1,400 x 1	14 x 0.01	140 x 0.1	14 x 0.01	-	20 x 0.02	-	14 x 0.01	14 x 0.01				
	MR53-50Z	50 x 0.05	-	-	3,600 x 5	36 x 0.05	350 x 0.5	35 x 0.05	-	50 x 0.05	-	36 x 0.05	35 x 0.05				
	MR53-12	192 x 0.1	12 x 0.01	1 x 0.001	-	-	-	135 x 0.1	1.35 x 0.001	192 x 0.2	12 x 0.01	-	135 x 0.1				
	MR53-50	800 x 0.5	50 x 0.05	4 x 0.005	-	-	-	570 x 0.5	5.7 x 0.005	800 x 1	50 x 0.05	-	570 x 0.5				
	MR53-100	1,600 x 1	100 x 0.1	8 x 0.01	-	-	-	1,150 x 1	11.5 x 0.01	1,600 x 2	100 x 0.1	-	1,150 x 1				
R55	MR55-20	320 x 0.5	20 x 0.02	1.5 x 0.002	-	-	-	220 x 0.2	2 x 0.002	320 x 0.5	20 x 0.02	-	220 x 0.2	0.6%	150%		
	MR55-50	800 x 1	50 x 0.05	4 x 0.005	-	-	-	570 x 0.5	5.7 x 0.005	800 x 1	50 x 0.05	-	570 x 0.5				
	MR55-100	1,600 x 2	100 x 0.1	8 x 0.01	-	-	-	1,150 x 1	11.5 x 0.01	1,600 x 2	100 x 0.1	-	1,150 x 1				
	MR55-200	-	200 x 0.2	16 x 0.02	-	2,300 x 2	-	2,200 x 2	22 x 0.02	-	200 x 0.2	2,300 x 2	2,200 x 2				
	MR55-400	-	400 x 0.5	32 x 0.05	-	4,600 x 5	-	4,500 x 5	45 x 0.05	-	400 x 0.5	4,600 x 5	4,500 x 5				
	MR55-1000	-	1,000 x 1	80 x 0.1	-	11,500 x 10	-	11,000 x 10	110 x 0.1	-	1,000 x 1	11,500 x 10	11,000 x 10				
	MR55-5000	-	5,000 x 5	400 x 0.5	-	55 x 0.05 kgFm	-	5,500 x 50	550 x 0.5	-	5,000 x 5	55 x 0.05 kgFm	550 x 0.5 Nm				

All sensors include a Plug & Test™ connector for interfacing directly with a 7i, 5i or 3i indicator. NIST-traceable certificate of calibration with data is also included.

\* Accuracy refers to the sensor only. Total accuracy includes the indicator's accuracy (±0.1% or ±0.2%). For example, the total accuracy of the MR50-50 sensor with 5i indicator equals ±0.35% + ±0.1% = ±0.45% FS.



# Wire Crimp Pull Testers

## Model WT3-201

Manual, 200 lbF / 1,000 N

The WT3-201 is an integrated solution for manual wire crimp pull testing requirements. An ergonomic lever allows for easy application of force. Adjustable terminal fixture contains multiple slots for diameters up to AWG 3 (0.25 in [6.3 mm]). USB output, data memory, and peak force capture are provided.

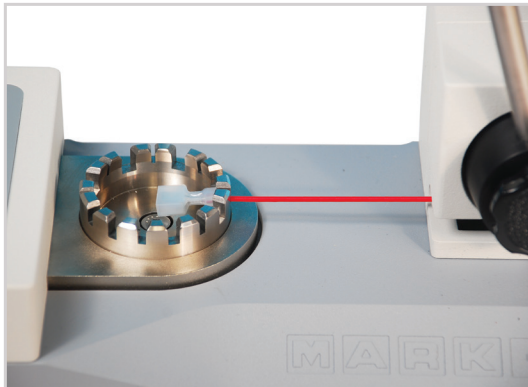

^ Adjustable wire terminal fixture accommodates wire diameter sizes up to 0.25 in (6.3 mm).



^ Unique knurled cam design effectively secures and pulls the loose end of the sample.



^ Ergonomic lever easily applies force and releases the sample.

## Features:

- **Peak force capture**
- **USB, RS-232, Mitutoyo, and analog outputs**
- **Data memory**  
1,000-point data memory with statistics (min, max, mean, standard deviation), and outputs.
- **Password protection**  
Passwords may be set for calibration and for individual keys, designed to protect the tester against unauthorized changes.
- **Automatic output**  
Automatic output / data storage / zeroing upon sample break helps automate testing processes

## Ordering Information

Model No.	Description
WT3-201	Wire terminal tester, 110V
WT3-201E	Wire terminal tester, 220V EUR
WT3-201U	Wire terminal tester, 220V UK
WT3-201A	Wire terminal tester, 220V AUS
WT3001	Carrying case
WT3002	Ring terminal fixture
WT3003	Machinable blank terminal fixture
AC1049	Calibration kit

# Wire Crimp Pull Testers



## Model WT3-201M

Motorized, 200 lbf / 1,000 N

The WT3-201M is an integrated motorized solution for destructive and non-destructive wire crimp pull testing requirements, such as pulling to a load and load holding. Adjustable terminal fixture contains multiple slots for diameters up to AWG 3 (0.25 in [6.3 mm]). USB output, data memory with time stamp, and peak force capture are provided, along with the ability to save up to 500 test profiles.

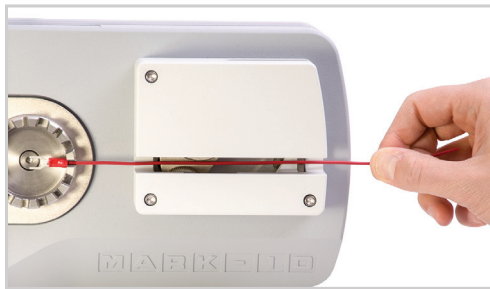

^ The tester automatically starts when the sample is loaded, and returns to home when the sample breaks. Adjustable terminal fixture accommodates wire diameters up to 0.25 in (6.3 mm)



^ As the test begins, serrated cams engage the sample. A pinch guard (red tab shown above) automatically rotates into position, for added safety.



^ Save and recall multiple profiles, for quick and accurate switchover to different test methods.

## Features:

- Measures real-time and peak force values
- Selectable test speed, w/high speed approach and reverse
- Auto-start upon sample insertion
- Auto-reverse at sample break or load
- USB, RS-232, Mitutoyo, and analog outputs
- 2,000-point data memory with statistics, output, and date and time stamp
- Save and recall up to 500 test profiles
- Pull to a specified load or maintain load for a specified period of time, as per UL 486A/B

## Ordering Information

Hardware	
WT3-201M	Motorized wire crimp pull tester, 110V
WT3-201ME	Motorized wire crimp pull tester, 220V EUR
WT3-201MU	Motorized wire crimp pull tester, 220V UK
WT3-201MA	Motorized wire crimp pull tester, 220V AUS
WT3002	Ring terminal fixture
WT3003	Machinable blank terminal fixture
WT3004	Carrying case
AC1049	Calibration kit
Controller Options	
WF010	Profiles
WF011	Pull to load limit
WF012	Load holding
WF013	Date and time stamp
WFCOMP	Complete options package (includes all Controller Options)

# Ergonomics Testing Kits

## Test push/pull muscle strength and functional task requirements

These kits make job task analysis and ergonomic testing analysis simple and accurate, ideal for workplace design, physical therapy, and ergonomic studies. Three kit series are available, each of which is available in capacities of 100 lbF (500 N), 200 lbF (1,000 N) and 500 lbF (2,500 N).



### Series EK5 Kits

- Series 5 digital force gauge
- USB cable
- Double- and single-handle cradles
- Clevis grip
- Padded attachments
- Implements and accessories
- Carrying case
- MESUR™ Lite software

### Series EK3 Kits

- Series 3 digital force gauge
- USB cable
- Double- and single-handle cradles
- Clevis grip
- Padded attachments
- Implements and accessories
- Carrying case
- MESUR™ Lite software

## Ordering Information:

Model No.	Description
EK3-100	Ergonomics testing kit, 100 lbF capacity
EK3-200	Ergonomics testing kit, 200 lbF capacity
EK3-500	Ergonomics testing kit, 500 lbF capacity
EK5-100	Ergonomics testing kit, 100 lbF capacity
EK5-200	Advanced ergonomics testing kit, 200 lbF capacity
EK5-500	Advanced ergonomics testing kit, 500 lbF capacity

All models include 110V AC adapters. Add suffix 'E' for euro plug (220V), 'U' for UK plug (220V), or 'A' for Australian plug (220V).

Example: EK5-100E, EK5-200U, EK3-500A







## MESUR™gauge / MESUR™gauge Plus software

MESUR™gauge and MESUR™gauge Plus expand the functionality of force and torque measuring instruments and test stands. Both programs share the ability to capture and display data in graphical format for load vs. time or load vs. travel vs. time. MESUR™gauge Plus adds the ability to control the motion of certain Mark-10 motorized test stands, coordinating motion control and data acquisition.

### Features:

- Tabulate and plot continuous or single-point data
- MESUR™gauge Plus starts and stops certain model motorized test stands, coordinating motion control and data collection with just one click
- Real time tabular and graphical data acquisition of load vs. time or load vs. travel vs. time
- Configurable start and stop test triggers (time, load, number of samples, or distance)
- Statistical calculations of acquired data. Automatically recalculates for custom ranges.
- One-click export to Excel
- Customize test setups for future recall
- Customize reports and templates
- Configure certain Mark-10 gauges and indicators through a simple interface
- View real time data on a large simulated instrument display

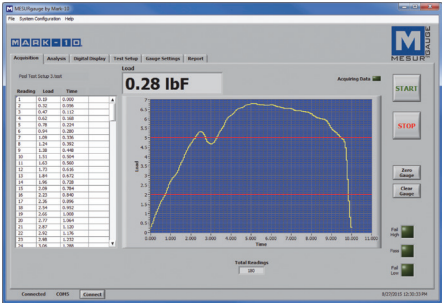

View real time data in graphical and tabular formats. Also, remotely zero the force gauge or test stand travel display.

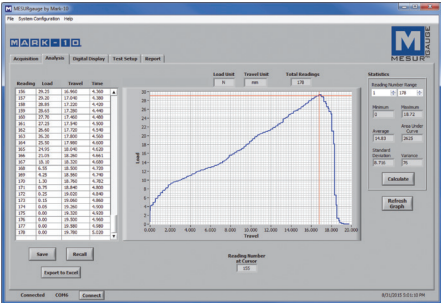

Analyze test data via x-y cursor and statistical calculations for specified regions. Tests may be saved and recalled, and data may be exported to Excel with one click.

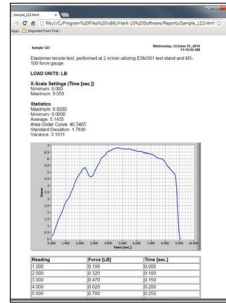

Generate reports, including test data, graph, statistics, date and time, and user-configurable fields.

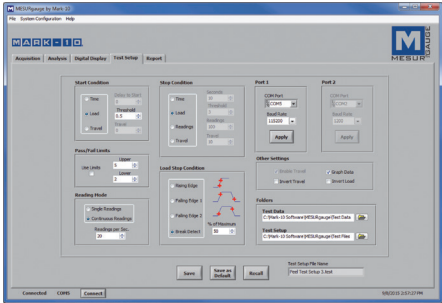

Configure start and stop conditions, such as load, break, time, or distance. Select either discrete data point collection or continuous data collection at up to 50 Hz.

### Ordering Information:

Model No.	Description
15-1004	MESUR™gauge software
15-1005	MESUR™gauge Plus software*
15-1004	Upgrade, MESUR™gauge to MESUR™gauge Plus*

\* Minimum required test stand controller firmware versions for motion control:  
 ESM303 / ESM303H: Front: 2.02.04, Main: 2.02.04  
 ESM1500: Front: 2.02.02, Main: 2.02.02



# Software



## MESUR™ Lite software

MESUR™ Lite is a basic data collection program included with Mark-10 gauges, indicators, and testers. MESUR™ Lite tabulates continuous or single point data from a gauge. Data saved in the gauge's memory can also be downloaded in bulk. One-click export to Excel allows for further data manipulation.

### Features:

- Tabulates continuous, single-point, or saved data from a gauge
- One-click export to Excel
- Configurable start and stop test triggers

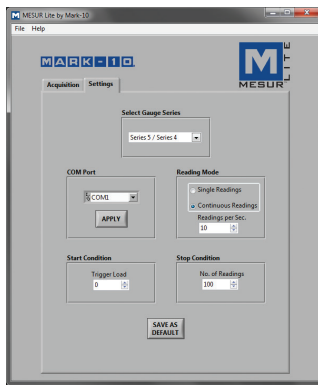

< The Settings tab allows the user to select gauge series, COM port, reading mode (discrete or continuous data collection), and start and stop conditions.

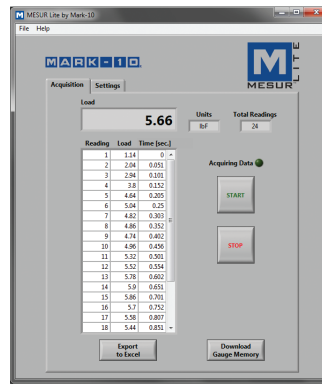

< The Acquisition tab displays the current reading and tabulates data. Also provides a means of downloading saved data from a Mark-10 instrument and one-click export to Excel.

## Software comparison chart

	MESUR™ gauge	MESUR™ gauge Plus	MESUR™ Lite
Compatible equipment	Instruments, test stands, travel displays		Instruments only
Type of data	Load vs. time / load vs. travel / custom		Load vs. time only
Motion control of motorized stands	X	✓	X
Data tabulation		✓	✓
Export to Excel		✓	✓
Graphing and analysis tools		✓	X
Max. number of data points	Unlimited		5,000
Data sampling rate	0.000001 - 50/sec.		0.1 - 10/sec.
Statistical calculations		✓	X
Available start conditions	Time, load, travel distance		Load only
Available stop conditions	Time, load, sample break, travel distance, number of readings		Number of data points only
Configurable pass / fail limits		✓	X
Reporting	Yes, with customizable fields and templates		X
Save and recall test data		✓	X
Save and recall multiple test setups		✓	X
Gauge configuration utility		✓	X
Large digital display		✓	X



## Model ES05

Force, Manual, 30 lbF / 150 N

The ES05 test stand is an economical and compact compression test stand for various testing applications. A spring-loaded lever allows for repeatable testing with up to 1.5" (38 mm) displacement, and the lever mechanism can be repositioned along the length of the column.

### Features:

- **Spring loaded lever mechanism**  
Convenient for repetitive testing.
- **Repositionable lever mechanism**  
Adds flexibility in test setups.
- **Compact size**  
Portable, small footprint.



## Models ES10 and ES20

Force, Manual, 100 lbF / 500 N

The ES10 and ES20 test stands are economical and compact push/pull solutions for many testing applications. Available in lever (ES10) or hand wheel (ES20) operation.

### Features:

- **Choice of lever (ES10) or hand wheel (ES20) operation**  
Lever action provides for quick testing at high speeds, while hand wheel action allows for fine positioning and better motion control.
- ▶ **Optional 1" dial or digital indicator**  
For spring testing, rubber and polymer testing, and more. Digital model displays in and mm. Also available as brackets only (no indicator).
- **Compact size**  
Portable, small footprint.



ES20

ES10





# Test Stands

## Model ES30

Force, Manual, 200 lbF / 1,000 N

The ES30 accommodates a wide range of sample shapes and sizes due to generous travel distance, daylight, and throat distance. Convenient side-mounted hand wheel operation makes testing easier.

### Features:

- **Side mounted hand wheel**  
Convenient loading method, offers more control over test speed.
- **Removable base**  
The entire base may be removed for alternative mounting.
- **Optional 6" & 12" digital travel displays**  
Useful in spring testing, rubber and polymer testing, and other applications.
- **Optional column extensions**  
For testing long samples. Available in lengths of 6" [152 mm], 12" [305 mm], and 24" [610 mm]. Custom lengths also available.



## Model TSA750 / TSA750H

Force, Manual, 750 lbF / 3,750 N

The TSA750 is a rugged stand for heavy duty testing applications requiring quick action. Lever operation allows the operator to produce 750 lbF with relatively little effort. Modular design allows for the force gauge bracket and lever mechanism to be repositioned along the column. Available in vertical and horizontal configurations.



TSA750

### Features:

- **Rack and pinion mechanism with lever operation**  
Allows for quick testing. The lever can be repositioned in 30° increments.
- **Adjustable travel stops**  
For limiting travel distance. Useful in repetitive testing.
- **Optional 6" digital travel display**  
Useful in spring testing, rubber and polymer testing, and other applications.



TSA750H





## Model TSB100

Force, Manual, 100 lbF / 500 N

The TSB100 is an economical lever operated test stand for many applications requiring quick action. Lightweight and compact design makes this stand portable for field testing. Modular design allows for the force gauge bracket and lever mechanism to be repositioned along the column. Removable base allows for a range of custom mounting configurations. Adjustable travel stops are available.

### Features:

- **Rack and pinion mechanism with lever operation**  
Allows for quick testing. The lever can be repositioned in 30° increments.
- **Removable base with loading table**  
A steel loading table with threaded holes is provided for grip or fixture mounting. The entire base may be removed for alternative mounting.
- **Optional 6" digital travel display**  
Useful in spring testing, rubber and polymer testing, and more.



## Model TSC1000 / TSC1000H

Force, Manual, 1,000 lbF / 5,000 N

The TSC1000 is a rugged stand for heavy duty testing requirements requiring fine position control without backdriving. Hand wheel operation allows the operator to produce gradual and repeatable force during testing. Modular design allows for the gauge mounting plate and housing to be moved along the length of the column. Removable base (TSC1000) or mounting legs (TSC1000H) allow for a range of custom mounting configurations.



TSC1000

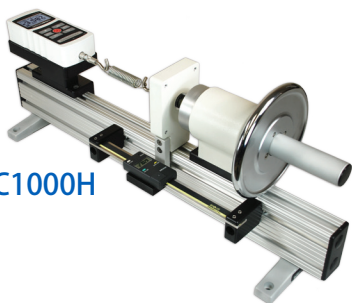

TSC1000H

### Features:

- **Inline hand wheel operation**  
Precision Acme screw and nut provide smooth operation over the entire 1,000 lbF range. Inline force minimizes column bending during testing.
- **Modular design**  
Adjustable components accommodate a wide range of testing configurations.
- **Optional 6" digital travel display**  
Useful in spring testing, rubber and polymer testing, and more.



# Test Stands

## Model TSF / TSFH

Force, Manual, 1,000 lbF / 5,000 N

The TSF is a rugged stand with a broad, rigid column, making it perfect for spring testing, high force tensile testing, and other applications. Precision side-mounted hand wheel operation is virtually effortless over the entire 1,000 lbF range, without backdriving. Modular design allows for the gauge mounting plate and housing to be moved along the length of the column. Removable base (TSF) or mounting legs (TSFH) allow for a range of custom mounting configurations.

### Features:

- **Side-mounted hand wheel operation**  
Ergonomic load method minimizes operator fatigue.
- **Exceptionally strong column**  
Rugged 3" x 3" column is durable and stiff, ideal for spring testing. Inline force minimizes column bending during testing.
- **Optional 6" digital travel display**  
Useful in spring testing, rubber and polymer testing, and other applications.

TSF

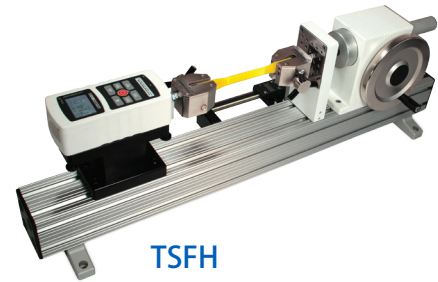

TSFH

## Model TST / TSTH

Torque, Manual, 100 lbFin / 11.3 Nm

The TST is ideal for a wide variety of torque testing applications up to 100 lbFin, including closure torque testing, fastener torque testing, and more. Smooth hand wheel operation ensures ease of use and a lever-operated slider with travel stops is provided for engaging and disengaging samples. The stand includes a torque loading table with tapped holes for grip mounting and a re-settleable angle indicator. Available in vertical and horizontal configurations.

### Features:

- **Lever operated slider**  
For simply and quickly engaging and disengaging samples.
- ▶ **Fixture mounting table with angle indicator**  
Steel table with threaded holes. Analog angle indicator with resolution of 2° may be reset.
- ▶ **Optional digital angle indicator**  
Useful in torsion spring testing, bottle cap testing, catheter testing, and other applications.

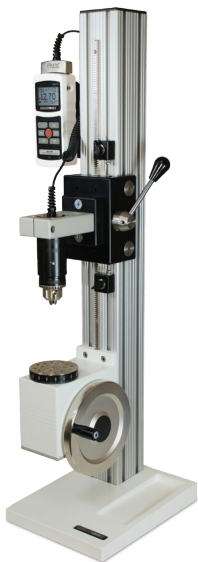

TST



TSTH

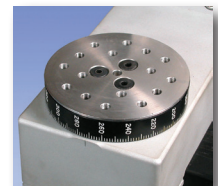



## Model ESM303

Force, Motorized, 300 lbF / 1,500 N

The ESM303 is a highly configurable single-column force tester for tension and compression measurement applications, with a rugged design suitable for laboratory and production environments. Sample setup and fine positioning are a breeze with available FollowMe™ force-based positioning - using your hand as your guide, push and pull on the force gauge or load cell to move the crosshead at a dynamically variable rate of speed.

With generous travel, clearance, and depth dimensions, a wide range of tests can be performed, including break testing, cycling, limit testing to a load or distance, loadholding, elongation testing, tensile testing, compression testing, and more. Satisfy various test methods through an easy-to-use menu, allowing the configuration of test speed, force and distance limits, cycling, preload, and many other functions, all protected by a password. Save up to 50 profiles to accommodate a range of test methods.

Force and travel data can be output to a PC for graphing and analysis using MESUR™ gauge software. Or, fully control the stand by a PC through a customwritten program with ASCII communication.

## Standard Features

- Selectable speed setting
- Upper and lower travel limit switches
- Adjustable, removal controller with intuitive menu navigation
- Password protection of test parameters
- Stepper motor-driven, producing smooth and quiet operation with no speed variation under load
- USB output of force vs. time or force vs. travel
- Compact footprint, suitable for crowded workbenches
- Ergonomic design, with smart, clean cable management
- Integrated electronics panel, easily removed and transported
- Adjustable mounting plate with T-slot base



^ Rugged aluminum up/down/stop keys are designed for industrial environments. *Zero Travel* and *FollowMe™* keys add convenience. Removable for remote use. See the following page for a full list of available functions.



^ Adjustable upper and lower solid state limit switches stop test stand travel with 0.001 in. [0.025 mm] repeatability.

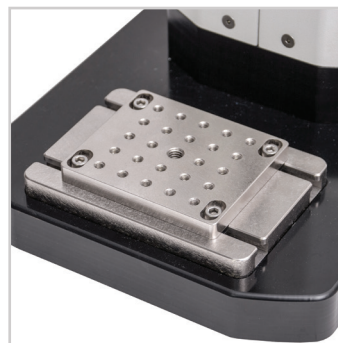

^ The mounting plate may be repositioned in the X- and Y-directions, for proper sample alignment. Matrix of threaded holes for fixture mounting.



^ All electronics are installed onto a single panel, easily accessible and removable for updating and service.



# Test Stands

## ESM303 - Additional Features & Items



^ Optional FollowMe™ function - Using your hand as your guide, push and pull on the load cell or force gauge to move the crosshead. Responsive enough for quick positioning as well as fine adjustments.



^ Increase the vertical clearance for tall samples with single column extensions. Three lengths are available - 6, 12 and 24 in [150, 300, and 600 mm].



^ Indicator / load cell adapter accommodates any Mark-10 indicator and Series R01 or R03 force sensors. Includes mounting hardware.



^ Double column extensions accommodate up to a 20 in. [508 mm] wide sample, or  $\varnothing 21.5$  in [ $\varnothing 546$  mm] round sample. Three heights are available - 6, 12 and 24 in [150, 300, and 600 mm]. Base contains rows of T-slots for fixture mounting.

## Specifications

Load capacity:	
< 24 in [610 mm]/min:	300 lbF [1.5 kN]
> 24 in [610 mm]/min:	200 lbF [1 kN]
Speed range:	
Standard:	0.5 - 13 in/min [13 - 330 mm/min]
Optional:	0.02 - 45 in/min [0.5 - 1,100 mm/min]
Maximum travel:	18.0 in [457 mm]
Speed setting accuracy:	$\pm 0.2\%$
Speed variation with load:	$\pm 0\%$ [Stepper motor driven]
Travel accuracy:	$\pm 0.002$ in per 10 in [ $\pm 0.05$ mm per 250 mm]
Travel resolution:	0.001 in [0.02 mm]
Limit switch repeatability:	$\pm 0.001$ in [0.03 mm]
Power:	Universal input 80-240 VAC, 50/60 Hz
Weight:	56.5 lb [25.6 kg]

## In The Box

The ESM303 test stand is shipped as shown, and includes the following accessories:

- (1) G1024 extension rod, 2"
- (1) G1028 small hook
- (1) G1038 medium hook
- (1) G1039 coupling, #10-32F/F
- (1) G1009 compression plate, 2" dia.
- (1) G1030 thread adapter, 5/16-18M to #10-32F
- (4) Thumb screw for force gauge / indicator
- (2) Thumb screw for limit switch
- (1) Allen wrench set
- (1) Control panel
- (1) Control panel mounting bracket and hardware
- (1) Power cord
- (1) Resource CD



## Horizontal Version ESM303H

For a horizontal orientation, consider Model ESM303H:

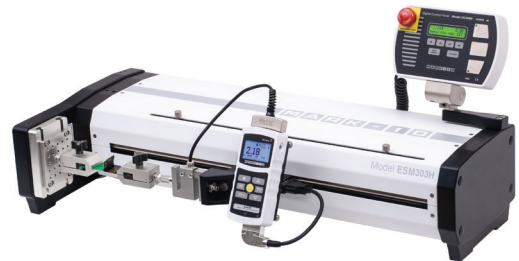





## ESM303 - Optional Functions

Any of the below option packages may be purchased at time of order or may be enabled in the field at a later date through a simple activation process. A complete options package is also available, including all of the below features at a discounted price. The stands are shipped in Demo Mode, during which time all available features are enabled for 160 hours of operation.

Feature	Part No.	Description	Requirements
FollowMe™	AF008	Crosshead movement responds to manually pushing or pulling on the force gauge shaft or load cell. Increasing force produces greater speeds. Ideal for setups and quick positioning.	- Series 7 or 5 gauge or indicator - 09-1214 interface cable
Travel indication	AF009	Travel is indicated on the control unit display, with output via USB. An internal scale utilizing Renishaw technology produces significantly higher accuracy than with conventional rotary encoder-based designs. Backlash and nonlinearity are virtually eliminated. The most recent position is memorized between power cycles.	- Field hardware installation required. - If data output to a PC is required, add 09-1214 and 09-1158 cables, and a Series 7 or 5 gauge or indicator.
Computer control	AF010	The ESM303 may be fully controlled by a PC through a custom-written program in any language supporting ASCII communications. Also responds to the legacy Chatillon TCD command set and legacy Nexygen TCD software (not available from Mark-10).	- Series 7 or 5 gauge or indicator - AF009 travel indication - AF011 programmable travel set points - 09-1214 interface cable - 09-1158 USB output cable
Programmable travel limits	AF011	The stand stops at or cycles between programmable upper and lower travel distances.	- AF009 travel indication option
Overload protection	AF012	Protects a force gauge or force sensor against overload. Program the desired percentage of full scale of the gauge. Adjustable analog output voltage setting allows the stand to interface with virtually any gauge with analog output.	- Series 7 or 5 gauge or indicator - 09-1214 interface cable
Auto return	AF013	The crosshead moves to a limit switch, force set point, travel position, or break, then stops and reverses direction at full speed to the opposite limit.	- If reversing at force set point: Series 7 or 5 gauge or indicator and 09-1214 interface cable - If reversing at travel limit: AF011 programmable travel limits option - If reversing at break: AF019 break detection option and 09-1214 interface cable
Cycling / dwell time	AF014	Same as auto return, but with the ability to program up to 100,000 cycles. Programmable dwell time for upper and lower limits (set independently) can be set up for up to 10,000 seconds.	- Same as auto return, at the same speed in each direction. Add AF016 for independent up and down speeds.
Independent up and down speeds	AF016	Individually configure speeds for the up and down directions.	---
Low speed range extension	AF017	Extends the standard speed range down to 0.02 in/min (0.5 mm/min).	---
High speed range extension	AF018	Extends the standard speed range up to 45 in/min (1,100 mm/min).	---
Break detection	AF019	Crosshead stops at a sudden drop in force. Programmable percentage of peak force.	- Series 7 or 5 gauge or indicator - 09-1214 interface cable
Load holding	AF020	Dynamically adjusts the crosshead position to maintain a programmed load for an indefinite or specified period of time.	- Series 7 or 5 gauge or indicator - If a specified time is required, add AF014 cycling / dwell time option - 09-1214 interface cable
Preload / sample touch	AF021	Stops the crosshead and/or zeroes the travel display at an initial preload - useful in tensile, compression, spring, elongation, and other applications. Preload is programmable as a percentage of force gauge/load cell full scale. Three modes: (1) stop, (2) stop and zero, and (3) zero without stopping.	- AF009 travel indication - Series 7 or 5 gauge or indicator - 09-1214 interface cable
Profiles	AF022	Save and recall sets of test parameters, such as speeds, travel limits, preloads, etc. Up to 50 profiles may be stored.	---
<b>Complete options package</b>	<b>AFCOMP</b>	<b>Includes all functions listed above, plus 09-1214 interface cable and 09-1158 USB cable. Requires a Series 7 or 5 gauge or indicator.</b>	

## Ordering Information\*

ESM303	Motorized test stand, 110V**
09-1214	Interface cable, gauge / indicator to ESM303
09-1158	USB output cable
AC1062	Load cell / indicator mounting kit
ESM303-001-1 / -2 / -3	Single column extension, 6 / 12 / 24 in. [150 / 300 / 600 mm]
ESM303-002-1 / -2 / -3	Double column extension, 6 / 12 / 24 in. [150 / 300 / 600 mm]

\* Controller options part numbers indicated in the table above.

\*\* ESM303 contains a universal power supply (80 - 240V) and includes a power cord with US plug. Add suffix 'E' for Euro plug, 'U' for UK plug, or 'A' for Australian plug. Ex: ESM303E



# Test Stands



## Models ESM1500LC & ESM1500FG

Force, Motorized, 1,500 lbf / 6.7 kN

The ESM1500 is a highly configurable single-column force tester for tension and compression measurement applications, suitable for laboratory and production environments. The ESM1500 may be used with an indicator-load cell combination (ESM1500LC) or with a force gauge (ESM1500FG). Sample setup and fine positioning are a breeze with available FollowMe™ force-based positioning - using your hand as your guide, push and pull on the load cell or force gauge to move the crosshead at a dynamically variable rate of speed.

With generous travel, clearance, and depth dimensions, a wide range of tests can be performed, including break testing, cycling, limit testing to a load or distance, loadholding, elongation testing, tensile testing, compression testing, and more. Satisfy various test methods through an easy-to-use menu, allowing the configuration of test speed, force and distance limits, cycling, preload, and many other functions, all protected by a password. Save up to 50 profiles to accommodate a range of test methods.

Force and travel data can be output to a PC for graphing and analysis using MESUR™ gauge software. Or, fully control the stand by a PC through a custom-written program with ASCII communication.

### Features:

- Compatible with indicators and load cells, as well as force gauges
- Adjustable, removal controller with intuitive menu navigation
- Password protection of test parameters
- Stepper motor-driven, producing smooth and quiet operation with no speed variation under load
- USB output of force vs. time or force vs. distance
- Compact footprint, suitable for crowded workbenches
- Ergonomic design, with smart, clean cable management
- Most electronics are housed in an integrated removable enclosure, easily removed and transported



^ Rugged aluminum up/down/stop keys are designed for industrial environments. Zero Travel and FollowMe™ keys add convenience. Removable for remote use. See the following page for a full list of available functions.



^ Adjustable upper and lower solid state limit switches stop test stand travel with 0.001 in. [0.025 mm] repeatability.



^ Most electronics are housed in an integrated enclosure, easily accessible and removable for updating and service.



^ A force gauge may be used with the Model ESM1500FG test stand, while an indicator and load cell are used with the Model ESM1500LC.



## ESM1500 - Additional Features & Items



Optional FollowMe™ function - Using your hand as your guide, push and pull on the load cell or force gauge to move the crosshead. Responsive enough for quick positioning as well as fine adjustments.



Optional mounting plate features a matrix of #10-32 threaded holes is provided, along with a 1/2-20 center hole.

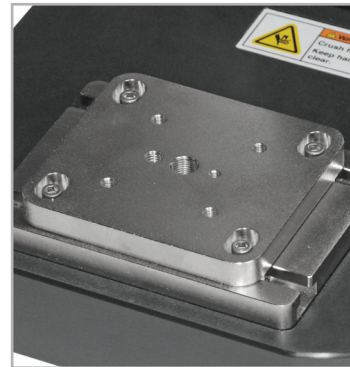

Optional mounting plate features three holes with #10-32, 5/16-18, and 1/2-20 thread sizes, along with an array of four 1/4-28 holes.

## Specifications

Load capacity:	
< 60 in [1,525 mm]/min:	1,500 lbf [6.7 kN]
> 60 in [1,525 mm]/min:	1,000 lbf [4.5 kN]
Speed range:	
Standard:	0.5 - 24 in/min [10 - 600 mm/min]
Optional:	0.001 - 90 in/min [0.02 - 2,300 mm/min]
Maximum travel:	32 in [813 mm]
Speed setting accuracy:	±0.2%
Speed variation with load:	±0% [Stepper motor driven]
Travel accuracy:	±0.002 in. per 10 in. [±0.05 mm per 250 mm]
Travel resolution:	0.001 in [0.02 mm]
Limit switch repeatability:	±0.001 in [0.03 mm]
Power:	Universal input 80-240 VAC, 50/60 Hz
Weight:	
Test stand:	198 lb [90 kg]
Shipping weight:	248 lb [113 kg]

## In The Box

The ESM1500LC and ESM1500FG test stands are shipped as shown at right, and include the following accessories:

- (1) G1081 eye end
- (1) G1080 anchor pin
- (2) G1079 lock ring, 3/4-16
- (2) G1088 spanner wrench
- (1) Load cell / indicator mounting kit (ESM1500LC)
- (1) Force gauge mounting kit (ESM1500FG)
- (1) USB cable
- (4) Thumb screw for indicator / force gauge
- (1) Allen wrench set
- (1) Control panel
- (1) Control panel mounting bracket with hardware
- (1) Power cord
- (1) Resource CD





# Test Stands

## ESM1500 - Optional Functions

Any of the below option packages may be purchased at time of order or may be enabled in the field at a later date through a simple activation process. A complete options package is also available, including all of the below features at a discounted price. The stands are shipped in Demo Mode, during which time all available features are enabled for 160 hours of operation.

Feature	Part No.	Description	Requirements
FollowMe™	SF008	Crosshead movement responds to manually pushing or pulling on the force gauge shaft or load cell. Increasing force produces greater speeds. Ideal for setups and quick positioning.	- Series 7 or 5 gauge or indicator
Travel indication	SF009	Travel is indicated on the control unit display, with output via USB. An internal scale utilizing Renishaw technology produces significantly higher accuracy than with conventional rotary encoder-based designs. Backlash and nonlinearity are virtually eliminated. The most recent position is memorized between power cycles.	-
Computer control	SF010	The ESM1500 may be fully controlled by a PC through a custom-written program in any language supporting ASCII communications. Also responds to the legacy Chatillon TCD command set and legacy Nexygen TCD software (not available from Mark-10).	- Series 7 or 5 gauge or indicator - SF009 travel indication - SF011 programmable travel set points
Programmable travel limits	SF011	The stand stops at or cycles between programmable upper and lower travel distances.	- SF009 travel indication option
Overload protection	SF012	Protects a force gauge or force sensor against overload. Program the desired percentage of full scale of the gauge. Adjustable analog output voltage setting allows the stand to interface with virtually any gauge with analog output.	- Series 7 or 5 gauge or indicator
Auto return	SF013	The crosshead moves to a limit switch, force set point, travel position, or break, then stops and reverses direction at full speed to the opposite limit.	- Reversing at force set point: Series 7 or 5 gauge or indicator - Reversing at travel limit: SF011 programmable travel limits option - Reversing at break: SF019 break detection option
Cycling / dwell time	SF014	Same as auto-return, but with the ability to program up to 100,000 cycles. Programmable dwell time for upper and lower limits (set independently) can be set up for up to 10,000 seconds.	- Same as auto-return, at the same speed in each direction. Add SF016 for independent up and down speeds.
Independent up and down Speeds	SF016	Individually configure speeds for the up and down directions.	-
Low speed range extension	SF017	Extends the standard speed range down to 0.001 in/min (0.02 mm/min).	-
High speed range extension	SF018	Extends the standard speed range up to 90 in/min (2,300 mm/min).	-
Break detection	SF019	Crosshead stops at a sudden drop in force. Programmable percentage of peak force.	- Series 7 or 5 gauge or indicator
Loadholding	SF020	Dynamically adjusts the crosshead position to maintain a programmed load for an indefinite or specified period of time.	- Series 7 or 5 gauge or indicator - If a specified time is required, order SF014 cycling / dwell time option
Preload / sample touch	SF021	Stops the crosshead and/or zeroes the travel display at an initial preload - useful in tensile, compression, spring, elongation, and other applications. Preload is programmable as a percentage of force gauge/load cell full scale. Three modes: (1) stop, (2) stop and zero, and (3) zero without stopping.	- SF009 travel indication - Series 7 or 5 gauge or indicator
Profiles	SF022	Save and recall sets of test parameters, such as speeds, travel limits, preload, etc. Maximum of 50 profiles may be stored.	-
Complete options package	SFCOMP	<b>Includes all functions listed above. Requires a Series 7 or 5 gauge or indicator.</b>	

## Ordering Information

ESM1500LC*	Motorized test stand with load cell mount, 110V*
ESM1500FG*	Motorized test stand with force gauge mount, 110V*
AC1055	Base plate, matrix of threaded holes
AC1054	Base plate, multiple center hole threads

\* ESM1500 contains a universal power supply (80 - 240V) and includes a power cord with US plug.

Add suffix 'E' for Euro plug, 'U' for UK plug, or 'A' for Australian plug. Ex: ESM1500LCE





## Model TSFM500-DC / TSFM500H-DC

Force, Motorized, 500 lbf / 2,200 N

Designed for compression and tension testing of springs, packaging, metals, fabrics, and other items requiring up to 500 lbf of force. Generous clearance and throat depth accommodate a broad range of sample shapes and sizes. The stand's durable and rigid column minimizes bend, making it particularly well suited for spring testing.

Speed is adjustable and a remote control unit provides added safety during testing. Other features include a manual fine adjustment knob and a stepper motor that prevents speed variation with load. The stand can cycle between limit switches or force limits. Overload protection protects a force gauge against damage from excessive force. Available in vertical and horizontal configurations.



TSFM500-DC



TSFM500H-DC

### Features:

- **Broad speed range**  
Set the speed from 0.01 - 6" [0.2 - 150 mm]/min.
- **No speed variation with load**  
Stepper motor control eliminates any speed variation, regardless of the force produced.
- **Removable base**  
The entire base may be removed for alternative mounting in a larger testing system.
- ◀ **Optional 6" digital travel display**  
Useful in spring testing, rubber and polymer testing, and other applications.
- ◀ **Limit switches**  
Upper and lower adjustable solid state limit switches. Repeatable to 0.001" [0.03 mm].
- **Cycle between limit switches or force limits**
- **Custom column lengths**







# Test Stands

## Model TSTM-DC / TSTMH-DC

Torque, Motorized, 100 lbFin / 11.3 Nm

Ideal for a wide variety of torque testing applications up to 100 lbFin (200 lbFin upgrade available), including closure torque testing, fastener torque testing, and other applications. Motorized clockwise and counterclockwise rotation produces highly precise and repeatable tests. Versatile modular design allows the stand to be configured for a variety of configurations while a lever-operated slider with travel stops makes engaging and disengaging samples quick and efficient. The stand includes a torque loading plate with tapped holes for grip and custom fixture mounting and a resettable angle indicator.

The stand can cycle between angle or torque limits. Overload protection protects a torque sensor against damage from excessive torque. Available in vertical and horizontal configurations.



TSTM-DC



TSTMH-DC

### Features:

- **Broad speed range**  
Set the rotational speed from 0.01 - 15 RPM (0.05 - 90°/s). Optional extended range.
- **No speed variation with load**  
Stepper motor control eliminates any speed variation, regardless of the torque produced.

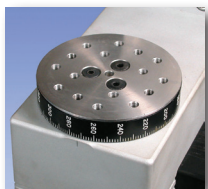

- ◀ **Fixture mounting table with angle indicator**  
Steel table with threaded holes. Analog angle indicator with resolution of 2° may be reset.
- **Integrated digital angle indicator**  
Measures in degrees or revolutions, with RS-232 output. USB converter available.

- **Cycle between angle or torque limits**
- **Custom column lengths**



## Specifications - Manual Test Stands

Model	Capacity lbF [N]	Maximum travel <sup>1</sup> in [mm]	Loading method	Travel rate in [mm]	Daylight <sup>2</sup> in [mm]
ES05	30 [150]	1.5 [38]	Spring-loaded lever	-	8 [203]
ES10	100 [500]	9 [229]	Lever	1.050 [26.7] / lever rev.	9 [229]
ES20			Top-mounted hand wheel	0.083 [2.1] / wheel rev.	
ES30	200 [1,000]	13 [330]	Side-mounted hand wheel	0.05 [1.3] / wheel rev.	14 [356] <sup>3</sup>
TSA750	750 [3,750]	with travel stops: 2.75 [70] without travel stops: 6 [152]	Rack & pinion, lever can be positioned in 30° increments	3.00 [76.2] / lever rev.	10.5 [267] <sup>3</sup>
TSA750H					14.5 [368] <sup>3</sup>
TSB100	100 [500]	6 [152]			21 [533] <sup>3</sup>
TSC1000	1,000 [5,000]	3.5 [89]	Inline hand wheel	0.10 [2.5] / wheel rev.	10 [254] <sup>3</sup>
TSC1000H					13 [330] <sup>3</sup>
TSF		4 [102]	Side-mounted hand wheel	0.013 [0.34] / wheel rev.	14 [356] <sup>3</sup>
TSFH					16.5 [419] <sup>3</sup>

## Specifications - Motorized Test Stands

Model	Capacity lbF [N]	Speed range in [mm]/min	Maximum travel <sup>1</sup> in [mm]	Daylight <sup>2</sup> in [mm]	Travel display	PC control (optional)
ESM303 / ESM303H	300 [1,500]	0.02 - 45 [0.5 - 1,100]	18.0 [457]	18.7 [475]	Internal, USB output, with optional programmable travel limits	Full
ESM1500	1,500 [6,700]	0.001 - 90 [0.02 - 2,300]	32.0 [813]	37.8 [959]		
TSFM500-DC / TSFM500H-DC	500 [2,200]	0.01 - 6 [0.2 - 150]	4.0 [102]	13.0 [331]	External, Mitutoyo output. Programmable travel limits not available.	All functions, except travel measurement

## Specifications - Torque Test Stands

Model	Torque capacity	Speed range	Controller features (cycling, PC control, etc.)	Angle indication	Programmable angle travel limits	Daylight <sup>2</sup> (w/R50 torque sensor) in [mm]
TST	100 lbFin [11.3 Nm]	12° / wheel rev. (manually operated)	N/A	Dial, optional digital angle display (no data output)	N/A	15.0 [381] <sup>3,6</sup>
TSTH						16.0 [406] <sup>3,6</sup>
TSTM-DC / TSTMH-DC		0.01 - 15 RPM [0.05 - 90°/s]	Included	Dial, integrated digital angle display with RS-232 output	Yes	16.0 [406] <sup>3,6</sup>

### Notes

- Maximum travel depends on the grips or fixtures used during testing. The dimensions indicate distances without the use of grips or fixtures.
- The clearance between the bottom of a mounted force gauge or sensor and the loading surface of the stand. Daylight will be reduced through the use of grips or fixtures. If the test sample size is close to the daylight figure above (or daylight less grip(s) or fixture(s)), a column extension may be necessary.
- Column extensions are available.
- All force test stands include force gauge mounting screws.
- All torque test stands include an adapter to secure the Series R50 torque sensor during testing. Adapters are also available for other torque sensors.
- With use of a Series R50 torque sensor.



# Test Stands

## Ordering Information

Test Stand Model No.	Description
Optional Item Part No.	
ES05	Test stand, lever operated, vertical, 30 lbF
ES10	Test stand, lever operated, vertical, 100 lbF
ES20	Test stand, hand wheel operated, vertical, 100 lbF
ES001	Dial indicator kit for ES10 / ES20, 1 x 0.001"
ES002	Digital indicator kit for ES10 / ES20, 1 x 0.0005" / 25 x 0.01 mm
ES30	Test stand, hand wheel operated, 200 lbF
ESM001	Digital travel display for ESM / ES30, 6 x 0.0005" [150 x 0.01 mm]
ESM004	Digital travel display for ESM / ES30, 12" x 0.0005 [300 mm x 0.01]
TSA750	Test stand, lever operated, vertical, 750 lbF
TSA750H	Test stand, lever operated, horizontal, 750 lbF
TSA001	Digital travel display for TSA750 / TSA750H, 6 x 0.0005" [150 x 0.01 mm]
TSA002	Horizontal / wall mounting kit for TSA750 / TSC1000
TSB100	Test stand, lever operated, vertical, 100 lbF
TSB001	Digital travel display for TSB100, 6 x 0.0005" [150 x 0.01 mm]
TSA002	Horizontal / wall mounting kit for TSA750 / TSC1000 / TSB100
TSB003	Travel stops kit for TSB100
TSC1000	Test stand, inline hand wheel operated, vertical, 1,000 lbF
TSC1000H	Test stand, inline hand wheel operated, horizontal, 1,000 lbF
TSC001	Digital travel display for TSC1000 / TSC1000H, 6 x 0.0005" [150 x 0.01 mm]
TSA002	Horizontal / wall mounting kit for TSA750 / TSC1000 / TSB100
TSF	Test stand, side-mounted hand wheel operated, vertical, 1,000 lbF
TSFH	Test stand, side-mounted hand wheel operated, horizontal, 1,000 lbF
TSFM500-DC*	Advanced test stand, motorized, vertical, 500 lbF, 110V
TSFM500H-DC*	Advanced test stand, motorized, horizontal, 500 lbF, 110V
TSF001	Digital travel display for Series TSF test stands, 6 x 0.0005" [150 x 0.01 mm]
TSF002	Horizontal / wall mounting kit for TSF / TST / TSTM
TSFM002	Limit switch kit for TSFM500 / TSFM500H
ESM303*	See catalog pages
ESM303H*	See catalog pages
ESM1500LC / ESM1500FG*	See catalog pages
TST	Test stand, hand wheel operated, torque, vertical, 100 lbFin
TSTH	Test stand, hand wheel operated, torque, horizontal, 100 lbFin
TSTM-DC*	Test stand, motorized, torque, vertical, 100 lbFin, 110V
TSTMH-DC*	Test stand, motorized, torque, horizontal, 100 lbFin, 110V
TST001	Digital angle indicator for Series TST test stands, 0.1° resolution, 110V
TST001E	Digital angle indicator for Series TST test stands, 0.1° resolution, 220V Euro

\*Includes 110V power cable. Add suffix 'E' for euro cable (220V), 'U' for UK cable (220V), or 'A' for Australian cable (220V).  
Example: ESM303E, TSTM-DCU



## Wire terminal grips

For securing wire terminals, cables, connectors, and other samples for pull testing.

Model No.	Capacity lbF [N]	Weight lb [kg]	ØA	B	C	D
G1001					0 - 0.125 [0 - 3.1]	
G1001-1	200 [1,000]	0.29 [0.13]	1.00 [25.4]	3.40 [86.4]	0.125 - 0.25 [3.1 - 6.3]	1.45 [36.8]
G1001-2					0.25 - 0.375 [6.3 - 9.5]	

Includes 5/16-18M to #10-32F adapter and #10-32 M/M stud with jam nuts

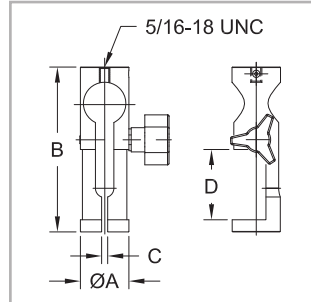

## Dual roller grips

For securing the ends of wire, cable, and tubing samples for pull testing. Engaging and disengaging samples is quick and easy via an efficient cam design and convenient side slot for sample insertion. Serrated steel rollers produce effective gripping characteristics.

Model No.	Capacity lbF [N]	Weight lb [kg]
G1002	200 [1,000]	0.19 [0.09]
G1002-1		0.24 [0.11]

Model No.	A	B	C	D	E	F	G
G1002	1.18 [30.0]	2.00 [50.8]	0.75 [19.1]	0 - 0.25 [0 - 6.3]	0.25 [6.4]	0.64 [16.5]	1.0 [25.4]
G1002-1	1.30 [33.0]			0.10 - 0.34 [2.5 - 8.6]			

Includes #10-32 M/M stud with jam nuts

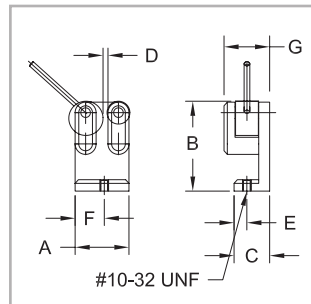

## Adjustable dual roller grips

This cam grip secures the ends of tubing, cables, and odd shaped samples for pull testing applications. Engaging and disengaging samples is quick and easy, with a side slot for sample insertion and serrated steel rollers. Rollers can be repositioned as required for the application.

Model No.	Capacity lbF [N]	Weight lb [kg]
G1085	200 [1,000]	0.51 [0.23]

Model No.	A	B	C	D	E	F	G
G1085	2.40 [61.0]	2.45 [62.2]	1.30 [33.0]	0 - 1.00 [0 - 25.4]	0.34 [8.6]	1.20 [30.5]	1.78 [45.3]

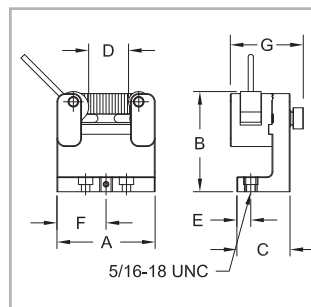





# Grips & Attachments (in[mm])

## Wire terminal grip, turret style

For securing wire terminals, cables, connectors, and other samples for pull testing. Indexing wheel contains grooves of varying widths to accommodate a wide range of sample shapes and sizes.

Model No.	Capacity lbF [N]	Groove Widths	Weight lb [kg]
G1076	200 [1,000]	0.01 [0.3], 0.03 [0.7], 0.04 [1.0], 0.06 [1.5], 0.08 [2.0], 0.09 [2.3], 0.11 [2.8], 0.12 [3.0], 0.14 [3.5], 0.15 [3.8], 0.17 [4.3], 0.18 [4.5], 0.20 [5.1], 0.21 [5.3], 0.23 [5.8], 0.25 [6.3]	1.00 [0.45]

Includes 5/16-18M to #10-32F adapter and #10-32 M/M stud with jam nuts

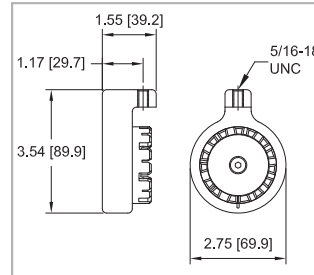

## High capacity wire / rope grip

For high capacity wire and rope pull testing applications. Secures the free end of the sample via a bollard and vise. Integrated eye end.

Model No.	Capacity lbF [kN]	Weight lb [kg]
G1092	2,000 [9]	6.0 [2.7]

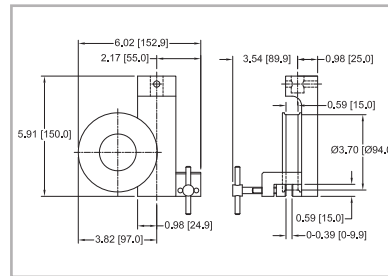

## High capacity wire terminal grip

For securing wire terminals, cables, connectors, and other samples for pull testing. Indexing wheel contains grooves of varying widths to accommodate a wide range of sample shapes and sizes. Integrated eye end.

Model No.	Capacity lbF [kN]	Groove Widths	Weight lb [kg]
G1093	2,000 [9]	0.08 [2.0], 0.12 [3.0], 0.16 [4.0], 0.20 [5.0], 0.24 [6.0], 0.31 [8.0], 0.39 [10.0], 0.46 [11.8]	6.4 [2.9]

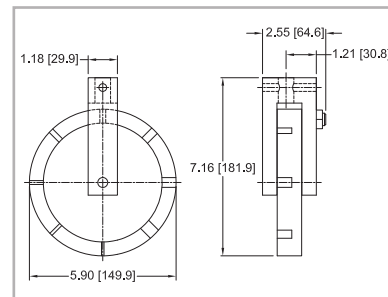

## High capacity eccentric roller grip

Features a serrated cam for effectively securing wires, plastics, textiles, and other materials in pull testing applications. Integrated eye end.

Model No.	Capacity lbF [kN]	Weight lb [kg]
G1094	2,000 [9]	7.4 [3.4]

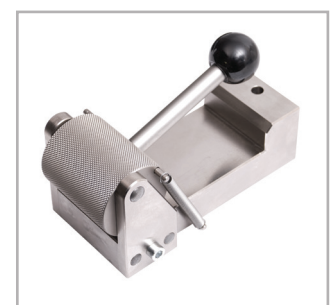
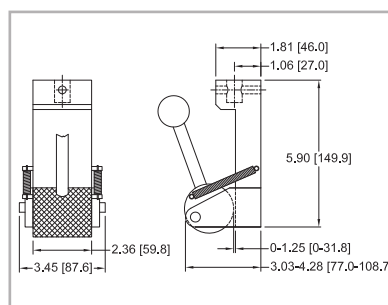



## Wedge grips

Heavy-duty grips designed for a range of tensile testing requirements up to 2,000 lbF [10 kN]. Self-tightening stainless steel serrated or rubber jaw faces engage the sample through a spring loaded knob and rack and pinion type mechanism. The jaws ride on rollers, eliminating jamming common in conventional wedge grips.

Model No.	A	B	C	D	E	F	G
G1061-1	1.95 [49.5]	2.45 [62.2]	0.375 [9.5]	0.95 [24.1]	5/16-18 UNC	0 - 0.25 [0 - 6.4]	0.62 [15.7]
G1061			0.75 [19.1]	1.50 [38.1]	5/16-18 UNC		1.00 [25.4]
G1061-2			1.00 [25.4]	1.75 [44.5]	1/2-20 UNC	0 - 0.20 [0 - 5.1]	1.13 [28.7]
G1061-3							

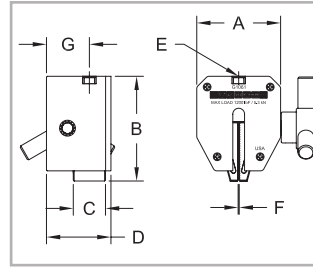

Model No.	Capacity lbF [N]	Weight lb [kg]	Jaw Material / Hardness	Included Adapters
G1061-1	200 [900]	0.50 [0.23]	416 SS / 55 RC	5/16-18M to #10-32F,
G1061	1200 [5,300]	0.80 [0.36]		#10-32 M/M stud*, 5/16-18 M/M stud*
G1061-2	2,000 [9,000]	0.90 [0.41]	Neoprene rubber Durometer = 70	1/2-20M to 5/16-18F, 1/2-20 M/M stud*, 5/16-18 stud*
G1061-3	50 [250]			



\* Includes jam nuts

## Parallel jaw grip

For general pull testing applications. Manually tightened serrated jaws may be individually positioned.

Model No.	Capacity lbF [N]	Weight lb [kg]	A	B	C	D
G1013	200 [1,000]	0.65 [0.29]	1.75 [44.5]	2.25 [57.2]	1.25 [31.8]	0 - 0.25 [0 - 6.3]

Includes 5/16-18M to #10-32F adapter and #10-32 M/M stud with jam nuts

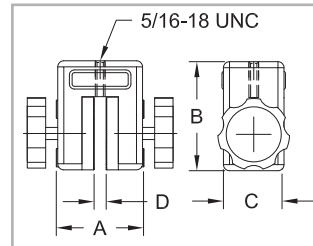

## Film and paper grips

For gripping film, paper, labels, packaging, and other thin materials for tensile and peel testing. Adjustable serrated interlocking jaws grip the sample securely.

Model No.	Capacity lbF [N]	Weight lb [kg]	A	B	C	D
G1008	100 [500]	0.31 [0.14]	1.25 [31.8]	2.50 [63.5]	1.2 [30.5]	0 - 0.15 [0 - 3.8]
G1015-1		0.57 [0.26]	3.00 [76.2]	3.00 [76.2]	1.90 [48.3]	0 - 0.50 [0 - 12.7]
G1015-2		0.67 [0.30]	5.00 [127.0]			
G1015-3		0.77 [0.35]	7.00 [177.8]			

Includes #10-32 M/M stud with jam nuts

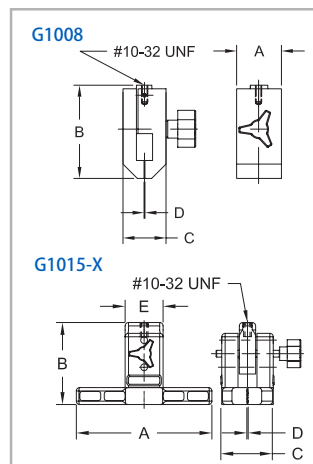



# Grips & Attachments (in[mm])

## Vise grip - standard

General purpose vise, for a wide range of tension and compression testing applications.

Model No.	Capacity* lbF [N]	Weight lb [kg]
G1074	500 [2,500]	2.00 [1.00]

A	B	C	D	E	F	G
1.00 [25.4]	0.50 [12.7]	1.50 [38.1]	2.00 [50.8]	2.50 [63.5]	0 - 1.50 [0 - 38.1]	1.00 [25.4]

Includes mounting hardware and adapters to mount to the following test stands: ESM303, ESM1500 (when ordered with optional AC1055 mounting plate), ESM301, ESM, ES30, TSC1000, TSF, TSFM500, ES10/ES20 (when ordered with optional AC1060 mounting plate)

\* Depending on sample characteristics

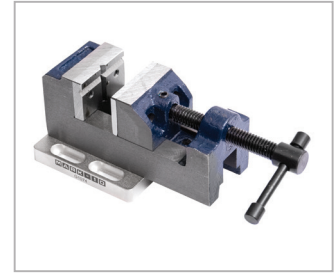
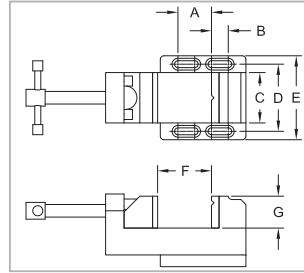

## Vise grip - self-centering

General purpose vise, for a wide range of tension and compression testing applications. Self-centering, replaceable jaws can be field-modified to improve sample gripping characteristics.

Model No.	Capacity* lbF [N]	Weight lb [kg]
G1070	500 [2,500]	5.85 [2.65]

A	B	C	D	E	F	G	H	I
3.78 [96.0]	0.30 [7.6]	2.76 [70.1]	2.33 [59.2]	2.00 [50.8]	0 - 2.00 [0 - 50.8]	1.12 [28.5]	2.00 [50.8]	2.00 [50.8]

Includes mounting hardware and adapters to mount to the following test stands: ESM303, ESM1500 (when ordered with optional AC1055 mounting plate), ESM, ES30, TSC1000, TSF, TSFM500, ES10/ES20 (when ordered with optional AC1060 mounting plate).

\* Depending on sample characteristics

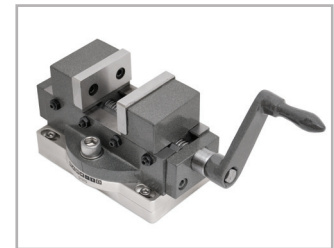
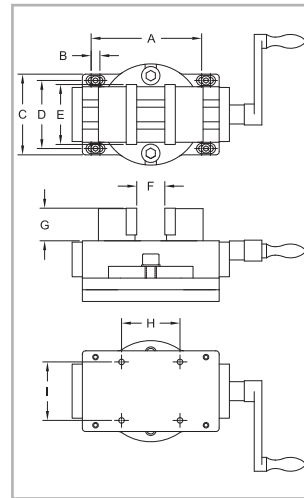

## Universal cap grip

For securing caps, lids, and other similar items for torque and pull testing. Accommodates a wide range of sample sizes, and can be used manually with a torque gauge or mounted to a test stand.

Model No.	Capacity	Weight lb [kg]
G1058	100 lbFin [11.3 Nm] or 50 lbF [250 N]	0.75 [0.34]

A	B	C	D	E	ØMIN - ØMAX
0.9 [22.9]	3.8 [96.5]	3.2 [81.3]	2.8 [71.1]	1.0 [25.4]	0.20 - 3.50 [5.1 - 89.0]

Includes #10-32 M/M stud with jam nuts

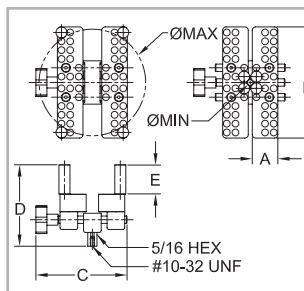



## Pneumatic film and paper grip

Fully enclosed, air-powered grip for seal strength testing of packaging, elongation testing of various materials, and other tensile testing requirements. Serrated interlocking jaws effectively grip samples for up to 100 lbF of force. The grip features a unique integrated open/close valve for quick sample engagement and disengagement. An air connection kit, consisting of tubing and fittings needed to connect two grips, is available separately. A membrane repair kit is also available. See below.

Model No.	Capacity	Weight lb [kg]	Max. pressure PSI (MPa)	Air input thread	A
G1046	100 lbF [500 N] at 100 PSI [0.86 MPa]	0.58 [0.26]	125 [0.86]	#10-32 UNF	0 - 0.13 [0 - 3.3]

Includes #10-32 M/M stud with jam nuts, one spare rubber membrane\*, one alcohol wipe, and two cotton swabs

The optional air connection kit consists of:

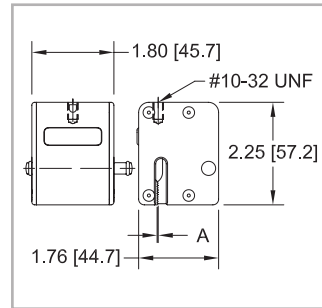
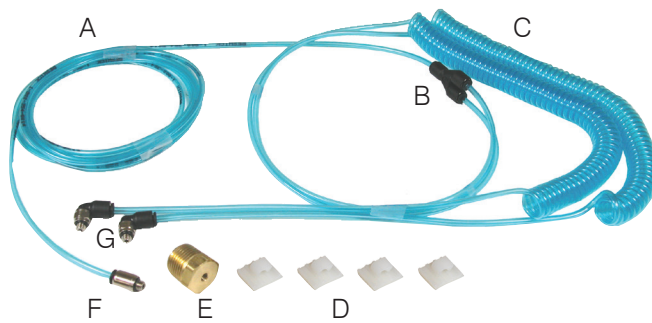

- A. Straight tubing, 1/8" OD, 1/16" ID, 5' length (qty. 1)
- B. Y-splitter (qty. 1)
- C. Coiled tubing, 1/8" OD, 1/16" ID, 8" retracted length (qty. 2)
- D. Adhesive-backed guide (qty. 4)
- E. Straight fitting, tubing to #10-32M (qty. 1)
- F. Thread adapter, #10-32F to 1/4" NPT M (qty. 1)
- G. Elbow fitting, tubing to #10-32M (qty. 1)

The optional maintenance kit\* consists of:

1. Rubber membrane (qty. 5)
2. Alcohol wipe (qty. 5)
3. Cotton swab (qty. 12)
4. Wrench set

Model No.	Description
AC1019	Air connection kit for G1046
AC1044*	Maintenance kit for G1046*

\* The flexible internal membrane actuating the movable jaw has a variable life expectancy dependent upon the maximum air pressure used and the quality of the compressed air. It should be free from impurities, solvents and oils. Since field conditions are outside of Mark-10's control, the standard 3-year warranty does not apply to the flexible membrane. For convenience, a spare membrane and alcohol wipe is included with every new grip. A membrane repair kit may be purchased from Mark-10.





# Grips & Attachments (in[mm])

## Miniature component grip

For testing small and hard-to-reach electronic and mechanical components. Slender profile allows this grip to be used in a wide range of applications.

Model No.	Capacity lbF [N]	Weight lb [kg]	A	B	C	D	E
G1003	30 [150]	0.05 [0.02]	0.5 [12.7]	1.7 [43.2]	0.5 [12.7]	0 - 0.07 [0 - 1.8]	0.15 [3.8]

Includes #10-32 M/M stud with jam nuts

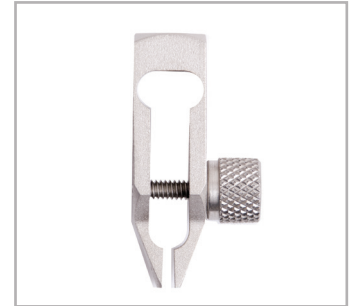
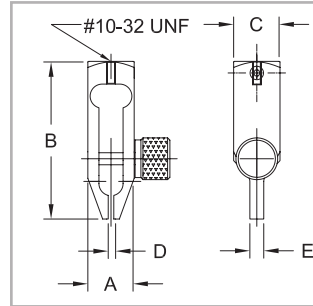

## Miniature wedge grip

For general low force pull testing applications. The serrated, self tightening steel jaws are easily opened with a spring-loaded lever.

A	B	C	D	E	F	G
1.37 [34.8]	2.49 [63.1]	0.19 [4.8]	0.32 [8.1]	#10-32 UNF	0 - 0.09 [0 - 2.3]	0.15 [3.9]

Model No.	Capacity lbF [N]	Weight lb [kg]
G1062	100 [500]	0.08 [0.04]

Includes #10-32 M/M stud with jam nuts

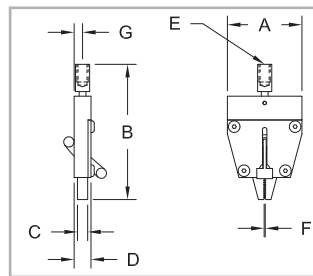

## 90° peel fixture

For the testing of adhesives, films, and various types of packaging. Maintains a 90° angle between the table and direction of pull. Optional limit switch stops travel on a motorized test stand, preventing cable breakage. Maximum load of 5 lbF [25 N].

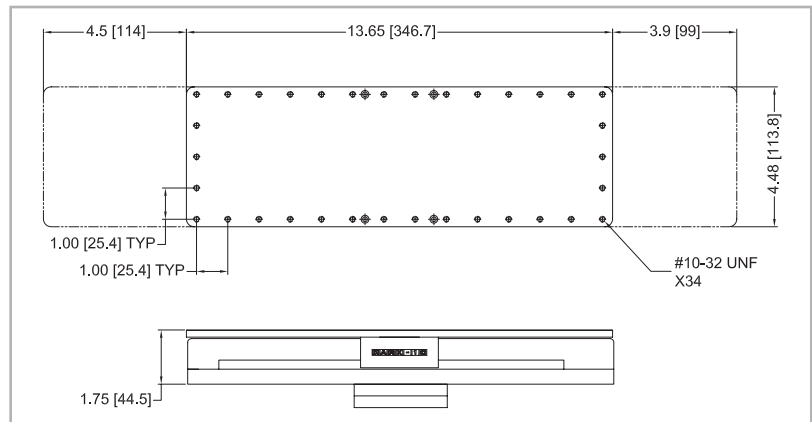

← G1045-1 optional limit switch

Model No.	Description
G1045	90° peel fixture
G1045-1	Limit switch for G1045

Includes mounting hardware and adapters to mount to the ESM303, ESM301, ESM, and ES30 test stands. Recommended for use with a motorized test stand.



## Coefficient of friction fixture

The G1086 can be used for a wide range of materials, ideal for conformance to ASTM D1894 and other relevant standards. Static and kinetic coefficients can be measured using the M5-2-COF gauge.

Model No.	Description
G1086	Coefficient of friction fixture

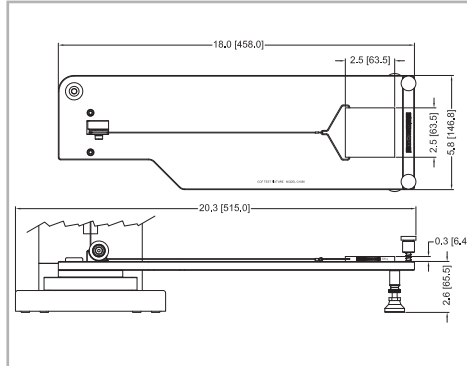

## Score bending fixture

Used to produce a 90° bend in fiber board materials and plastics to conform to TAPPI standard T829. Set of upper and lower dies.

Model No.	Capacity lbF [N]	Weight lb [kg]
G1071	50 [250]	Upper die: 0.15 [0.67] Lower die: 0.30 [0.14]

Upper die includes a 5/16-18M to #10-32F thread adapter and #10-32 M/M stud with jam nuts.

Lower die includes mounting hardware for the following test stands: ESM303, ESM1500 (when ordered with optional AC1055 mounting plate), ESM301, ESM, ES30, TSC1000, TSF, TSFM500, ES10/ES20 (when ordered with optional AC1060 mounting plate).

A motorized test stand is required to fulfill the test speed requirement of TAPPI T829.

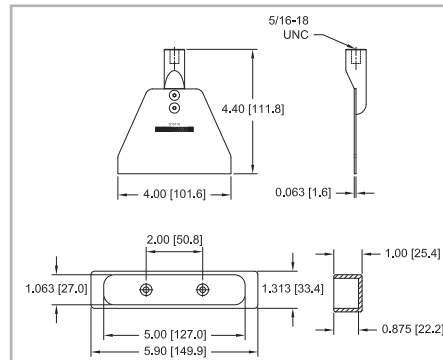

## Opening force fixture

Used to determine the opening force of flat folded cartons along score lines. Set of upper and lower dies.

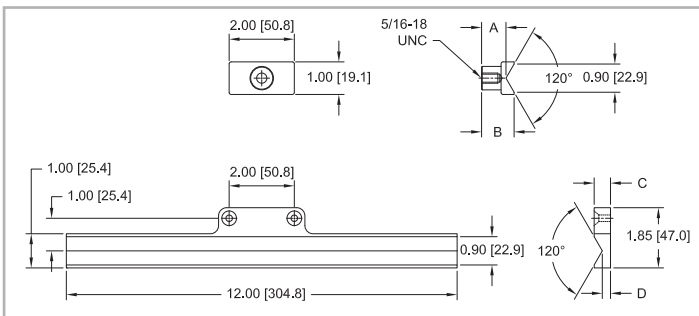

Model No.	Capacity lbF [N]	Weight lb [kg]	A	B	C	D
G1072	50 [250]	Upper die: 0.06 [0.03] Lower die: 0.10 [0.05]	0.75 [19.1]	1.00 [25.4]	0.50 [12.7]	0.25 [6.4]

Upper die includes a 5/16-18M to #10-32F thread adapter and #10-32 M/M stud with jam nuts.

Lower die includes mounting hardware for the following test stands: ESM303, ESM1500 (when ordered with optional AC1055 mounting plate), ESM301, ESM, ES30, TSC1000, TSF, TSFM500, ES10/ES20 (when ordered with optional AC1060 mounting plate). A motorized test stand is recommended.

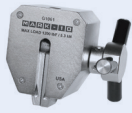

# Grips & Attachments (in[mm])

## 3-point / 4-point bend fixtures

Family of bend fixtures designed for 3-point and 4-point bend testing of plastics, metals, ceramics, tubing, and many other materials. Two base sizes are available, along with an upper anvil, and optional roller diameters. Use a base-anvil combination for 3-point bend testing or two bases for 4-point bend testing.

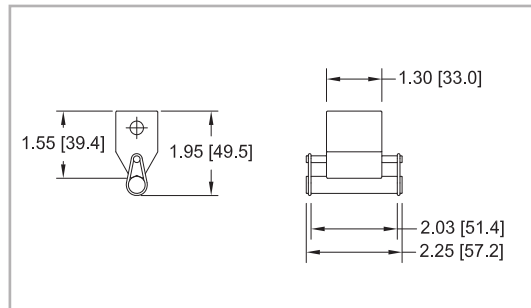
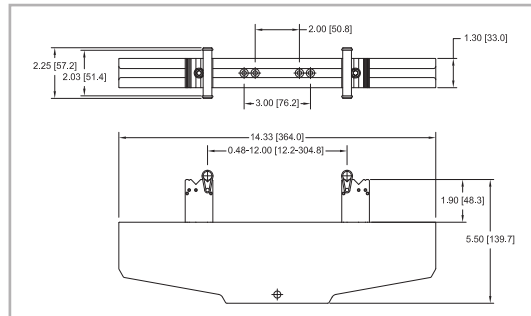
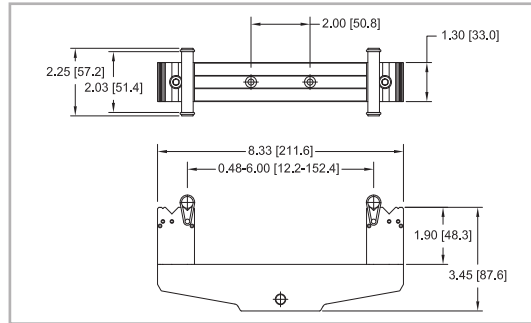

Model No.	Capacity lbF [kN]	Weight lb [kg]	Housing material	Block material	Roller material	Includes
G1095	500 [2.5]	3.0 [1.3]	2024 Al	303 SS	416 SS, hardened	Screws for test stand mounting, two 10 mm dia. rollers and o-rings
G1096	2,000 [10]	7.1 [3.2]	2024 Al	303 SS	416 SS, hardened	Screws for test stand mounting, two 10 mm dia. rollers and o-rings
G1097	2,000 [10]	0.5 [0.2]	303 SS	-	416 SS, hardened	10 mm. dia. roller and o-rings

## Optional Items

Model No.	Description
AC1067	Rollers for bend fixtures, 1 mm dia., set of 4
AC1067-1	Rollers for bend fixtures, 2 mm dia., set of 4
AC1067-2	Rollers for bend fixtures, 5 mm dia., set of 4





## Loop tack fixture

Designed for tack force testing of pressure-sensitive adhesives, in conformance with ASTM D6195 and related standards. A looped sample is loaded onto the test strip, and the closed end of the loop is secured by an upper grip (not included - suggested model: G1008). The test strip may be indexed in three positions, allowing for three tests to be performed between cleaning cycles.

Model No.	Capacity lbF [N]	Weight* lb [kg]	Test strip material
G1098	5100 [500]	1.10 [0.5]	2.38 [60.4]

Includes a 5/16-18 M/M stud with jam nuts.

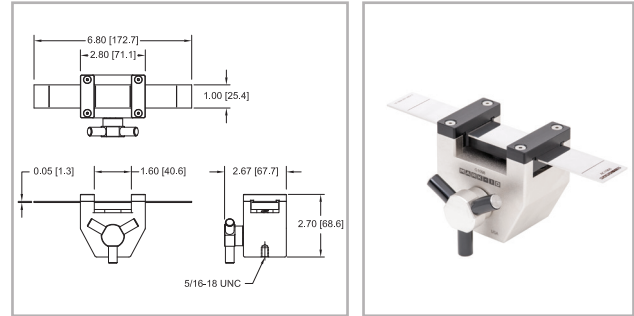

## Syringe compression fixture

Designed to test compression force of a syringe plunger, as per ISO 7886-1 and other relevant standards.

Consists of:

1. Frame
2. Replaceable blank inserts (4)
3. Cup tray
4. G1009 compression plate

Model No.	Capacity lbF [N]	Weight lb [kg]
G1089	100 [500]	1.89 [0.86]

Includes 5/16-18 M/M stud with jam nuts

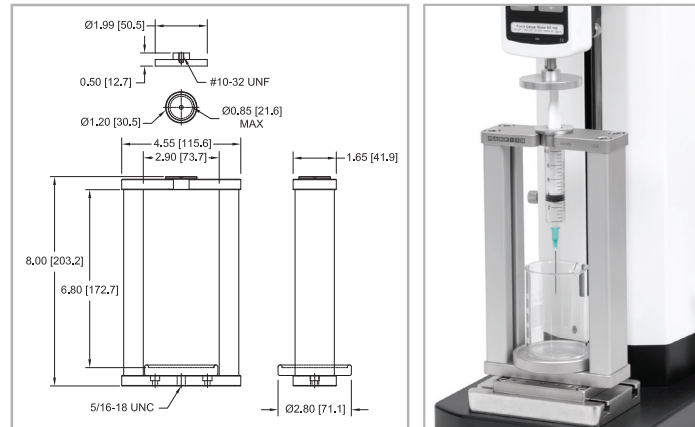

## Miniature filament grip

For securing small diameter wires and filaments. The sample wraps around the bollard and the loose end is secured by the adjustable jaw. Integrated swivel ensures sample alignment under load.

Model No.	Cap. lbF [N]	Weight lb [kg]	A	B	C	D	E	F	G
G1078	50 [250]	0.06 [0.03]	2.38 [60.4]	1.09 [27.7]	0.10 [2.5]	0.10 [2.5]	0.55 [14.1]	Ø0.45 [11.4]	0.20 [5.1]

Includes #10-32 M/M stud with jam nuts

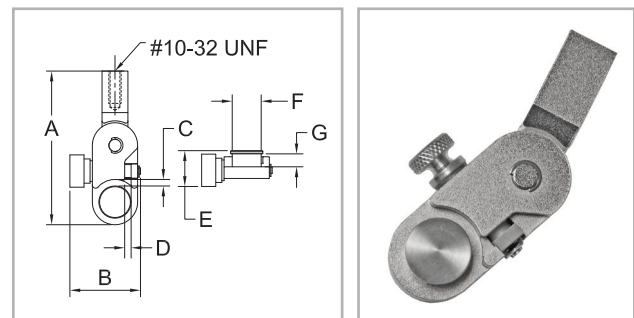





# Grips & Attachments (in[mm])

## Clevis grip

This grip is designed for ergonomic assessment, spring testing, and other pull testing applications.

Model No.	Capacity lbF [N]	Weight lb [kg]	A	B	C	D	E	ØF
G1077	500 [2,500]	0.29 [0.13]	1.70 [43.2]	1.25 [31.8]	0.38 [9.7]	0.85 [21.6]	1.45 [36.8]	0.25 [6.3]

Includes a 5/16-18M to #10-32F thread adapter, 5/16-18 M/M stud with jam nuts, and #10-32 M/M stud with jam nuts

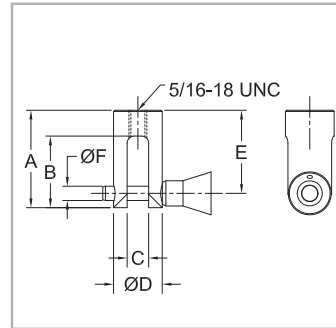

## High capacity clevis grip

This high capacity grip is designed for spring testing and pulling testing applications. Integrated eye end.

Model No.	Capacity lbF [kN]	Weight lb [kg]
G1090	2,000 [9]	0.78 [0.35]

A	B	C	ØD	E	F	ØG	ØH	ØI
2.77 [70.4]	1.80 [45.7]	0.55 [14.0]	1.40 [35.6]	2.32 [58.9]	0.87 [22.1]	0.63 [15.9]	0.32 [8.0]	0.38 [9.7]

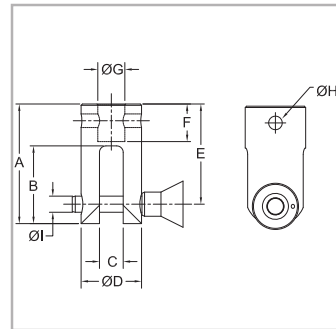

## Multi-jaw grip

For gripping round or odd shaped items. Jaws expand and retract by rotating the housing.

Model No.	Cap.	Weight lb [kg]	ØA	B	C	ØD	E	ØF
G1056	100 lbF [500 N]	0.30 [0.14]	3.50 [88.9]	2.30 [58.4] MAX	1.63 [41.4]	1.55 [39.4]	0.075 [1.91]	0.40 - 1.25 [10.2 - 31.7]

Includes #10-32 M/M stud with jam nuts

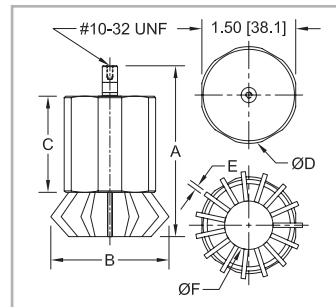

## Rubber tip

Simulates a finger for testing pushbuttons, membrane switches, touch-screen panels, keyboards, etc.

Model No.	Capacity lbF [N]	Weight lb [kg]
G1011	50 [250]	0.01 [0.004]

Includes #10-32 M/M stud with jam nuts

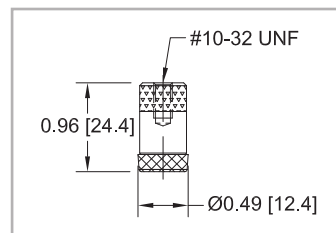



## Universal bottle grip

For gripping bottles and containers in closure torque testing applications. Eight rubber edged gripping arms secure a wide range of sample shapes and sizes and may be individually positioned at angles up to 180°. Mounts directly to Series TST torque test stands, most force test stands, and G1045 90° peel fixture for applications such as top load testing and 90° peel testing.

Model No.	Capacity lbFin [Nm]	Weight lb [kg]	ØA
G1023	100 [11.3]	1.50 [0.7]	4.80 [122.0] MAX

Model No.	Description
G1068	Adapter, G1023 to force test stand / G1045 fixture

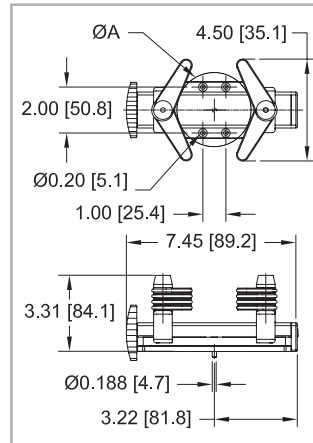

G1023 includes mounting hardware for Series TST test stands or G1068 adapter.

G1068 includes mounting hardware for the G1023 fixture and the following test stands: ESM303, ESM1500 (when ordered with optional AC1055 mounting plate), ESM301, ESM, ES30, TSC1000, TSF, TSFM500, ES10/ES20 (when ordered with optional AC1060 mounting plate)

## Compression plates

For compressing springs, foams, cartons, aerosol cans, and many other products.

Model No.	Capacity lbF [N]	Weight lb [kg]	ØA	Thread
G1009	200 [1,000]	0.08 [0.04]	2.0 [51.0]	#10-32 UNF
G1009-1	500 [2,500]	0.27 [0.12]	3.0 [76.2]	5/16-18 UNC

G1009 includes #10-32 M/M stud with jam nuts

G1009-1 includes 5/16-18M/M stud with jam nuts

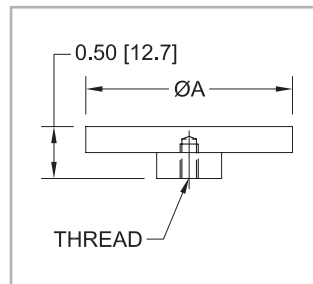

## High capacity compression plates

For compression spring testing, top load testing, and other applications. Integrated eye end.

Model No.	Capacity lbF [kN]	Weight lb [kg]	ØA	B	Material
G1087	2,000 [9]	1.50 [55.9]	3.78 [96.0]	1.28 [32.5]	303 SS
G1087-1	2,000 [9]	0.63 [0.29]	2.20 [55.9]	1.18 [30.0]	

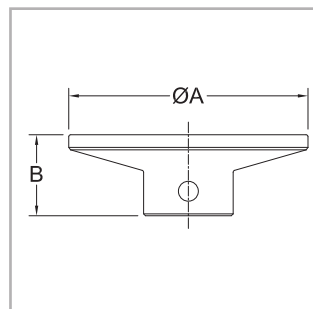

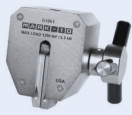

# Grips & Attachments (in[mm])

## Universal V-jaw grip

For gripping round objects. Serrated, reversible aluminum jaws effectively grip a wide range of sample shapes and sizes. Mounts directly to Series R50 and R51 torque sensors, Mark-10 force gauges, and force test stands.

Model No.	Torque Capacity lbFin [Nm]	Force Capacity lbF [N]	Weight lb [kg]
G1053	100 [11.3]	100 [500]	0.39 [0.18]

A	B	C	ØD1*	ØD2*
3.1 [78.7]	2.0 [50.8]	1.6 [40.6]	1.10 - 1.55 [27.9 - 39.4]	0.65 - 1.10 [16.5 - 27.9]

\* Jaws must be reversed to switch from ØD1 to ØD2

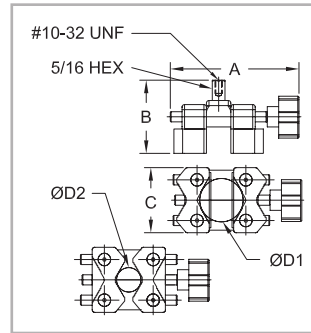

Includes #10-32 M/M stud with jam nuts

## Chuck grips

For securing round samples, fixtures, or bits. G1010-X is typically used in force measurement applications, mounted to a force gauge or test stand. G1022-X is typically mounted to a Series TST torque test stands for torque measurement applications.

Model No.	Capacity lbF [N]	Weight lb [kg]	ØA	ØB	ØC
G1010	30 lbF [150 N]	0.35 [0.16]	0.062 - 0.375 [1.6 - 9.5]	N/A	N/A
G1010-1		0.25 [0.11]	0.028 - 0.25 [0.7 - 6.3]		
G1010-2		0.66 [0.30]	0.078 - 0.5 [2.0 - 12.7]		
G1022-1	100 lbFin [11.3 Nm]	0.50 [0.23]	N/A	0.188 [4.7]	0.028 - 0.250 [0.7 - 6.3]
G1022-2					0.062 - 0.375 [1.6 - 9.5]
G1022-3					0.078 - 0.500 [2 - 12.7]

G1010-X includes a #10-32 M/M stud with jam nuts

G1022-X includes mounting hardware for Series TST torque test stands

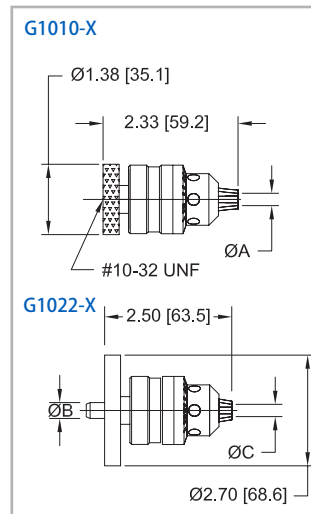

## Extension rods

For use between a force gauge and another attachment, such as a hook or compression plate.

Model No.	Capacity lbF [N]	Weight lb [kg]	A	ØB	C	D
G1024	200 [1,000]	0.05 [0.023]	5.0 [127.0]	0.25 [6.4]	#10-32F	#10-32M
G1024-1		0.02 [0.009]	2.0 [50.8]			
G1024-2		0.01 [0.005]	1.0 [25.4]			
G1031	500 [2,500]	0.25 [0.113]	5.0 [127.0]	0.50 [12.7]	5/16-18F	5/16-18M
G1031-1		0.10 [0.045]	2.0 [50.8]			
G1031-2		0.25 [0.113]	1.0 [25.4]			

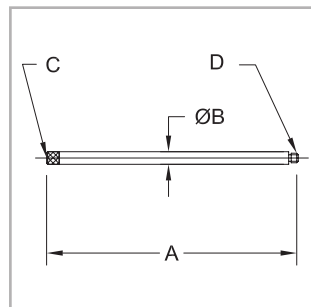



## Hooks

For pull testing of various samples.

Model No.	Capacity lbF [N]	Weight lb [kg]	RA	B	ØC	D
G1028	20 [100]	0.010 [0.005]	0.05 [1.3]	1.00 [25.4]	0.10 [2.5]	#10-32F
G1038	200 [1,000]	0.020 [0.009]	0.20 [5.1]	1.50 [38.1]	0.19 [4.8]	#10-32M
G1035	500 [2,500]	0.050 [0.023]	0.30 [7.6]	1.90 [48.3]	0.28 [7.1]	5/16-18M
G1042	1,000 [4500]	0.320 [0.145]	0.5 [12.7]	4.10 [104.1]	0.45 [11.4]	1/2-20M

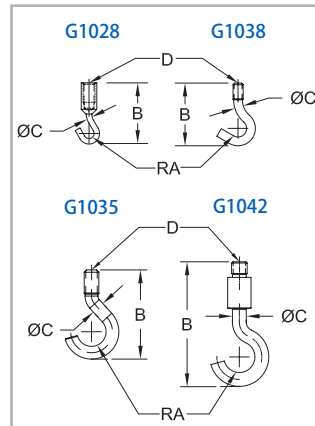

## Flat heads

For compression testing of buttons, membrane switches, etc.

Model No.	Capacity lbF [N]	Weight lb [kg]	ØA	B	C
G1029	200 [1,000]	0.01 [0.005]	0.5 [12.7]	0.5 [12.7]	#10-32F
G1036	500 [2,500]	0.06 [0.027]	0.75 [19.1]	0.87 [22.1]	5/16-18F

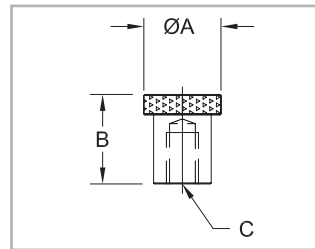

## Padded attachments

For applications in physical therapy and ergonomics, including muscle strength testing, job task requirements, and more.

Model No.	Capacity lbF [N]	Weight lb [kg]
G1019	500 [2,500]	0.03 [0.01]
G1020	500 [2,500]	0.13 [0.06]
G1021	500 [2,500]	0.25 [0.11]

Includes a 5/16-18M to #10-32F adapter and #10-32M/M stud with jam nuts

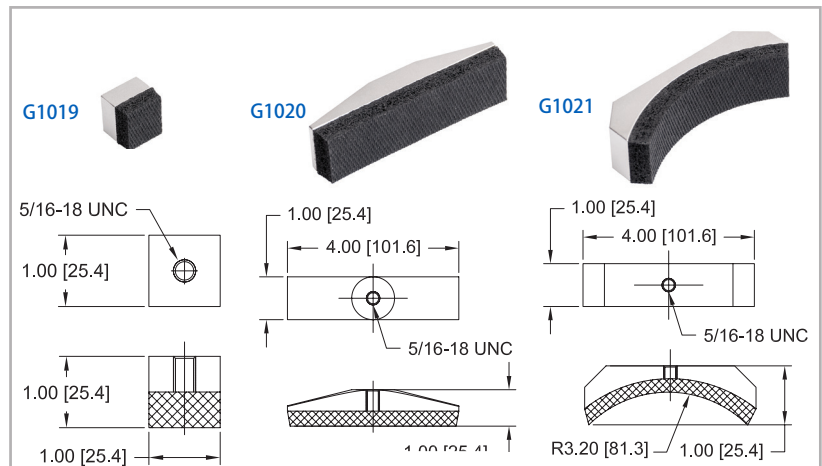

## Swivel adapters

For use between any grip and force gauge to provide a swiveling action for proper sample alignment.

Model No.	Capacity lbF [N]	Weight lb [kg]	A	B
G1018-1	200 [1,000]	0.12 [0.05]	#10-32M	#10-32F
G1018-2	500 [2,500]	0.27 [0.12]	5/16-18M	5/16-18F

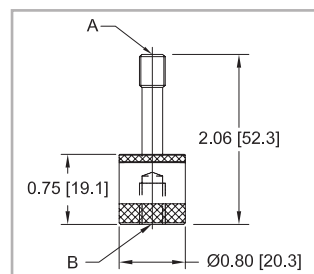



# Grips & Attachments (in[mm])

## Chisel points

For compression testing applications.

Model No.	Capacity lbF [N]	Weight lb [kg]	A	ØB	C
G1025	200 [1,000]	0.003 [0.001]	0.50 [12.7]	0.25 [6.4]	#10-32F
G1032	500 [2,500]	0.040 [0.018]	1.00 [25.4]	0.50 [12.7]	5/16-18F

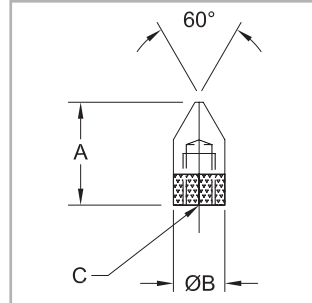

## Cone points

For various compression and puncture testing applications.

Model No.	Capacity lbF [N]	Weight lb [kg]	A	ØB	C
G1026	200 [1,000]	0.003 [0.001]	0.50 [12.7]	0.25 [6.4]	#10-32F
G1033	500 [2,500]	0.030 [0.014]	1.00 [25.4]	0.50 [12.7]	5/16-18F

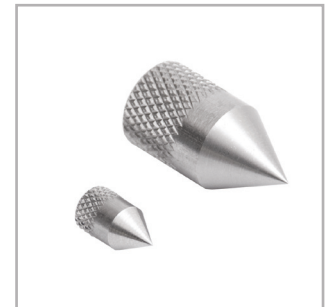
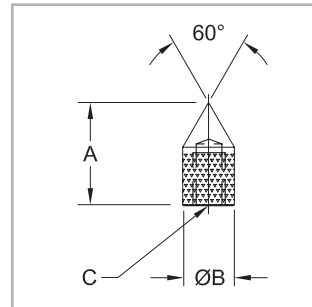

## V-grooves

For compression testing of round or odd-shaped samples.

Model No.	Capacity lbF [N]	Weight lb [kg]	A	ØB	C	D
G1027	200 [1,000]	0.004 [0.002]	0.50 [12.7]	0.25 [6.4]	#10-32F	0.08 [2.0]
G1034	500 [2,500]	0.040 [0.018]	1.00 [25.4]	0.50 [12.7]	5/16-18F	0.25 [6.4]

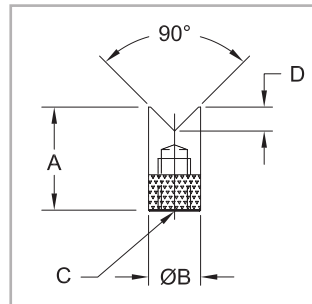





## Thread adapters & couplings

For use between force gauge shafts, test stands, grips, and attachments.

Model No.	Capacity lbF [N]	Length	Thread A	Thread B	
G1050	100 [500]	0.75 [19.1]	#4-40M	#10-32F	
G1051		0.55 [14.0]	#4-40M	#10-32M	
G1039	200 [1,000]	0.75 [19.1]	#10-32F	#10-32F	
G1030		0.50 [12.7]	5/16-18M	#10-32F	
G1057		1.00 [25.4]	#10-32F	M6F	
G1060		0.50 [12.7]	#10-32M	#10-32M	
G1047		0.75 [19.1]	#10-32M	M4F	
G1048		0.75 [19.1]	M4M	#10-32F	
G1054		0.75 [19.1]	M6M	#10-32F	
G1063		1.30 [33.0]	#10-32M	5/16-18F	
G1040		500 [2,500]	0.92 [23.4]	5/16-18M	5/16-18M
G1037			1.00 [25.4]	5/16-18F	5/16-18F
G1049	1.25 [31.8]		M6M	5/16-18F	
G1059	1.13 [28.7]		5/16-18F	1/2-20F	
G1041	1.06 [26.9]		1/2-20M	5/16-18M	
G1066	0.75 [19.1]		5/16-18F	1/2-20M	
G1067	0.75 [19.1]		1/2-20F	10-32M	
G1069	1.25 [31.8]		5/16-18F	1/4-28M	
G1091	1,000 [5,000]	1.30 [33.0]	1/2-20F	1/2-20F	
G1044		Adapter plate, 1/2-20F. Compatible with the following test stands: ESM303, ESM1500 (when ordered with optional AC1055 mounting plate), ESM301, ESM, TSF, TSFM500(-DC), TSB100, TSC1000, and ES10/ES20 (when ordered with optional AC1060 mounting plate). Mounting hardware included. Pictured at right.			





# Accessories



## Eye end adapters

These adapters provide a commonly accepted industry method of attaching fixtures to load cells and test frames. They prevent grip rotation and allow for quick removal and installation.

Several thread sizes and variations are available to suit most common test frames, load cells, grips, and force gauges. Eye ends and adapters are available individually or as kits.

◀ Eye ends and adapters are shown with Mark-10 wedge grips, test stand, and force gauge

### Base / load cell adapter kits

AC1047	AC1047-1	AC1047-2	AC1047-3	Item No.	Part No.	Qty.
X				2	G1081	1
	X			2	G1081-1	1
		X		2	G1081-2	1
			X	2	G1081-3	1
X	X	X	X	3	G1080	1
X	X	X	X	1	G1079	2



### Grip adapter kits

AC1046	AC1046-1	AC1046-2	Item No.	Part No.	Qty.
X			4	G1083	1
	X		4	G1083-1	1
		X	4	G1083-2	1
X	X	X	1	G1079	1



### Force gauge adapter kits

AC1045	AC1045-1	AC1045-2	Item No.	Part No.	Qty.
X			6	G1082	1
		X	2	G1081-2	1
	X		6	G1082-1	1
X			5	G1084	1
	X		5	G1084-1	1
X	X	X	1	G1079	2
X	X	X	3	G1080	1
		X	5	G1084-2	1



### Load cell / test frame configuration

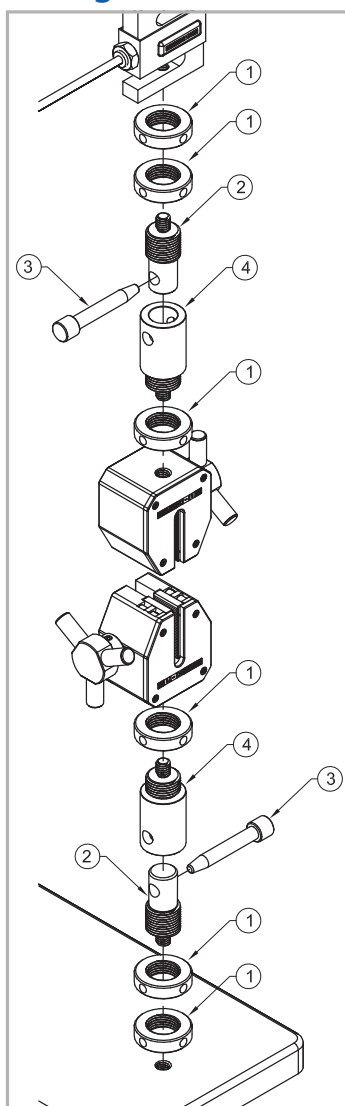

### Force gauge configuration

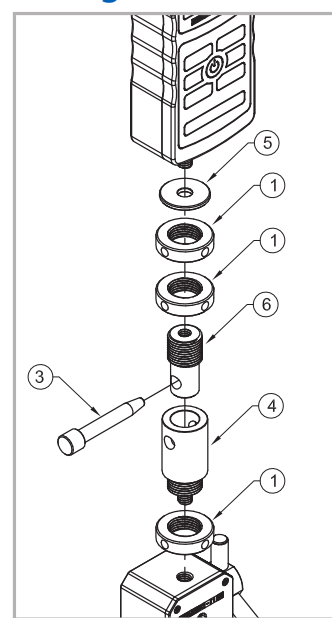

Item No.	Part No.	Description
1	G1079	Lock ring, 3/4-16
2	G1081	Eye end, #10-32M
	G1081-1	Eye end, 5/16-18M
	G1081-2	Eye end, 1/2-20M
	G1081-3	Eye end, 1/4-28M
3	G1080	Anchor pin
4	G1083	Eye end adapter, #10-32M
	G1083-1	Eye end adapter, 5/16-18M
	G1083-2	Eye end adapter, 1/2-20M
5	G1084	Washer, 0.20 ID
	G1084-1	Washer, 0.32 ID
	G1084-2	Washer, 0.51 ID
6	G1082	Eye end, #10-32F
	G1082-1	Eye end, 5/16-18F
Not shown	G1088	Spanner wrench (p.62)



## G1084-X jam washers

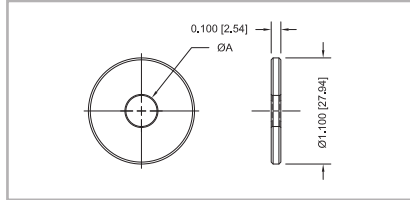

Part No.	ØA	Weight lb [kg]
G1084	0.20 [5.1]	0.03 [0.01]
G1084-1	0.32 [8.2]	0.03 [0.01]
G1084-2	0.51 [12.9]	0.03 [0.01]

## G1079 lock ring

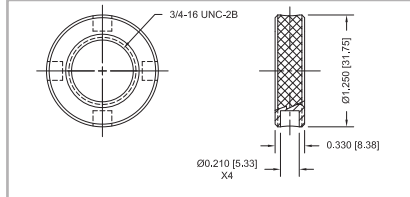

Weight lb [kg]
0.07 [0.03]

## G1081-X eye ends

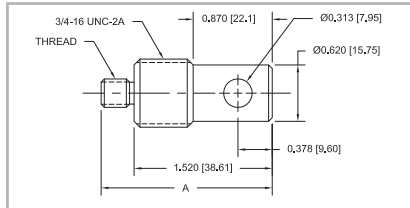

Part No.	A	Thread	Weight lb [kg]	Capacity lbF [N]
G1081	1.82 [46.2]	#10-32	0.13 [0.06]	200 [1,000]
G1081-3	1.87 [47.5]	1/4-28	0.13 [0.06]	200 [1,000]
G1081-1	1.88 [47.8]	5/16-18	0.14 [0.06]	500 [2,500]
G1081-2	2.02 [51.3]	1/2-20	0.15 [0.07]	2,000 [10,000]

## G1082-X eye ends

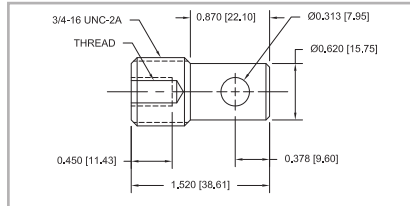

Part No.	Thread	Weight lb [kg]	Capacity lbF [N]
G1082	#10-32	0.13 [0.06]	200 [1,000]
G1082-1	5/16-18	0.14 [0.05]	500 [2,500]

## G1083-X eye ends

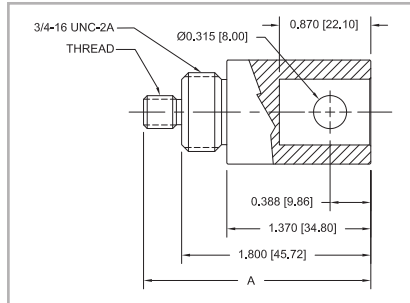

Part No.	A	Thread	Weight lb [kg]	Capacity lbF [N]
G1083	2.10 [53.3]	#10-32	0.26 [0.12]	200 [1,000]
G1083-1	2.16 [54.9]	5/16-18	0.26 [0.12]	500 [2,500]
G1083-2	2.30 [58.4]	1/2-20	0.28 [0.13]	2,000 [10,000]

## G1080 anchor pin

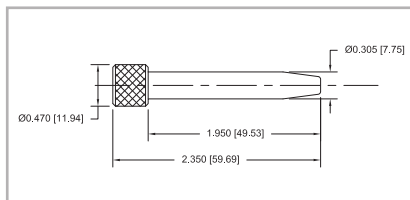

Weight lb [kg]
0.06 [0.03]

## G1088 spanner wrench



# Accessories

## Double handle grips

For use in ergonomics testing, job task analysis, and physical therapy. Includes four gauge mounting screws.



Model No.	Description
AC1002	Double handle grip for Series 7/5/4 gauges
AC1003	Double handle grip for Series 3/2 gauges

## Single handle grips

For use in ergonomics testing, job task analysis, and physical therapy. Includes four gauge mounting screws.



Model No.	Description
AC1002-1	Single handle grip for Series 7/5/4 gauges
AC1003-1	Single handle grip for Series 3/2 gauges

## AC adapter/chargers

110V and 220V models available, for use with all Mark-10 gauges, indicators, and testers.\*

Model No.	Description
AC1030	AC adapter / charger, 110V
AC1031	AC adapter / charger, 220V EUR
AC1032	AC adapter / charger, 220V UK
AC1035	AC adapter / charger, 220V AUS

\*Except Series MG and MGT gauges manufactured before September 2010.



## Replacement battery

Rechargeable 8.4V NiMH battery, for use with Mark-10 gauges, indicators, and testers.



Model No.	Description
08-1026	Battery, rechargeable, 8.4V



## Tabletop stand for indicators

Features an angle adjustment and thru holes for workbench mounting. Includes four gauge mounting screws.



Model No.	Description
AC1008	Stand, indicator, tabletop

## Competitor gauge mounting kits

Model	Description	Compatible Test Stands
AC1020	Gauge mounting kit, Chatillon DFE/DFS/DFX/LG	ES10, ES20, ES30, ESM, ESM301(L)
AC1021	Gauge mounting kit, Chatillon DFM	
AC1022	Gauge mounting kit, Chatillon DFIS	
AC1023	Gauge mounting kit, Mecmesin AFG/BFG	
AC1024	Gauge mounting kit, Imada Z2/DS2/DPZ/DPS	
AC1025	Gauge mounting kit, Shimpo FGV/FGE	
AC1037	Gauge mounting kit, Chatillon DFE/DFS/DFX/LG	TSA750, TSC1000, TSF
AC1038	Gauge mounting kit, Chatillon DFM	
AC1039	Gauge mounting kit, Chatillon DFIS	
AC1040	Gauge mounting kit, Mecmesin AFG/BFG	
AC1041	Gauge mounting kit, Imada Z2/DS2/DPZ/DPS	
AC1042	Gauge mounting kit, Shimpo FGV/FGE	
AC1061	All Mark-10 force gauges	Chatillon TCD200 / TCM201 / LTCM

## Force gauge mounting plate kits

Universal kits suitable for all Mark-10 force gauges in OEM and custom mounting applications.



AC1052



AC1058

Model No.	Description
AC1052	Mounting plate kit, 0.12 - 500 lbf [0.5 - 2,500 N] Mark-10 force gauges
AC1007	Mounting plate kit, 0.12 - 2,000 lbf [0.5 N - 10 kN] Mark-10 force gauges

## Axial compensator

Designed to compensate for axial movement in torque tests of threaded fasteners, bottle caps, etc. The axial compensator has a hex tail which fits into the chuck of a Series R50 or TT03 torque gauge, and includes mounting hardware to mount to a G1053 or G1058 grip.

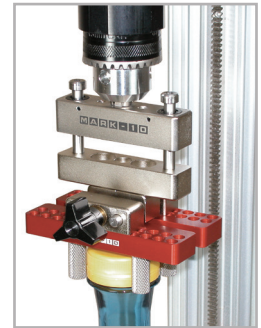

Model No.	Description
AC1029	Axial compensator

## Tabletop mounting kits for torque sensors

For securing Series R50, R52, and Models MR54-200/400 torque sensors to a workbench.



AC1006

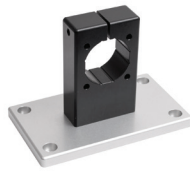

AC1007



AC1010

Model No.	Description
AC1006	Mounting kit, R52, tabletop
AC1007	Mounting kit, R50, tabletop
AC1010	Mounting kit, MR55-200/MR55-400, tabletop

## Test stand mounting kits for remote sensors

Refer to the compatibility table below:



Model No.	Sensors	Test Stands
AC1015	Series R51	TST-series torque test stands
AC1016	Models MR55-200 & MR55-400	TST-series torque test stands
AC1018	Series R01, Series R03	All force test stands, except ESM303(H), ESM1500, TSB100 and ESMH
AC1062	Series R01, Series R03	ESM303





# Accessories

## Cap torque tester calibration kit

This calibration kit is designed to permit the field calibration of any Series TT01 cap torque tester. The kit contains a complete set of attachments required to mount the tester to a bench, as well as the necessary brackets and cable to mount weights.



Model No.	Description
AC1036	Calibration kit, weights not included

## Wire pull tester calibration kit

This calibration kit is designed to permit the field calibration of a WT3-200, WT3-201, or WT3-201M wire crimp pull tester. The kit contains a complete set of attachments required to mount the tester to a bench, as well as the necessary brackets to mount weights (weights not included).



Model No.	Description
AC1049	Calibration kit for wire crimp pull tester

## Communication adapters



Model No.	Description
RSU100	Adapter, RS-232 to USB (includes USB cable and driver CD)
MRS100	Adapter, Mitutoyo to RS-232, 25-pin
MRS100A	Adapter, Mitutoyo to RS-232, 9-pin

## Footswitch for Series 7 instruments

Automates common force gauge functions for improved testing ergonomics and efficiency, eliminating the need for multiple key presses. Up to three functions may be programmed for a single footswitch activation, such as request reading, zero the display, etc.



Model No.	Description
AC1051	Footswitch for Series 7 / 7i

## Cables



Model No.	Description	Compatible Instruments
09-1214	Interface cable, gauge to test stand crosshead	Series 7, 5, 4 instruments with ESM303, ESM1500 test stands
09-1252	Interface cable, indicator to test stand crosshead	Model M7i and M5i indicators with ESM303H test stand
09-1162	Interface cable, gauge to test stand controller	Series 7, 5, 4 instruments with ESM301(L), ESMH-DC, TSFM500(H)-DC, ESMH-DC test stands
09-1165	USB cable, type micro B to A	Series 7, 5, 4, 3, TT01, TT02, TT03, TT05, WT3-201(M) instruments to PC
09-1158	USB cable, type B to A	ESM303, ESM1500 test stands to PC
09-1163	Serial cable, gauge to RS-232, DB-9	Series 7, 5, 4, TT01, TT02, TT05, WT3-201(M) instruments
09-1164	Cable, gauge to Mitutoyo SPC	Series 7, 5, 4, TT01, TT02, TT05, WT3-201(M) instruments
09-1166	Analog cable, gauge to dual banana plug	Series 7, 5, 4, TT01, TT02, TT05, WT3-201(M) instruments
09-1056	Serial cable, test stand controller to RS-232 DB9	ESM301(L), ESMH-DC, TSFM500(H)-DC, ESMH-DC test stands
09-1066	Cable, travel display to Mitutoyo SPC	Mitutoyo travel display mounted to ES30, TSA750(H), TSB100, TSC1000(H), TSF(H), TSFM500(H), TSFM500(H)-DC test stands
09-1180	Cable, set point / overload protection, gauge to test stand	Series 7, 5, 4 instruments with ESM, TSFM500, ESMH, TSTM test stands



Cables for legacy products are also available. See website for details.

# Dimensional Drawings (in[mm])

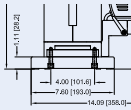

## Force Gauges

### Series 7

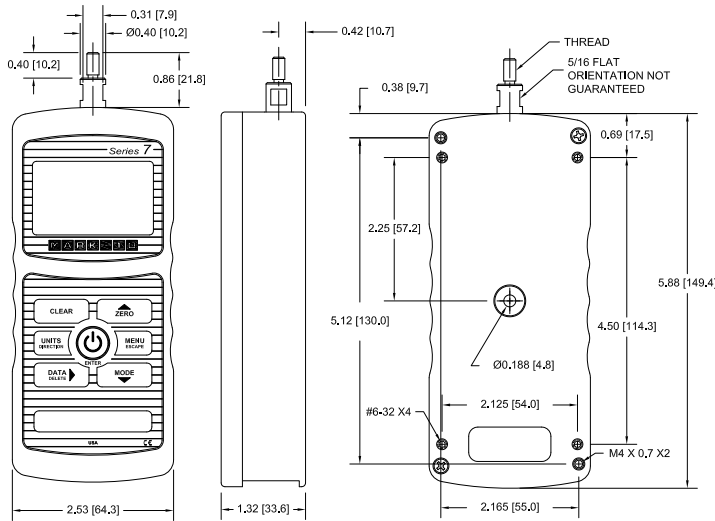

	Thread
M7-012 - M7-100	#10-32M UNF
M7-200 - M7-500	5/16-18M UNC

### Series 5 Models M5-012 - M5-500

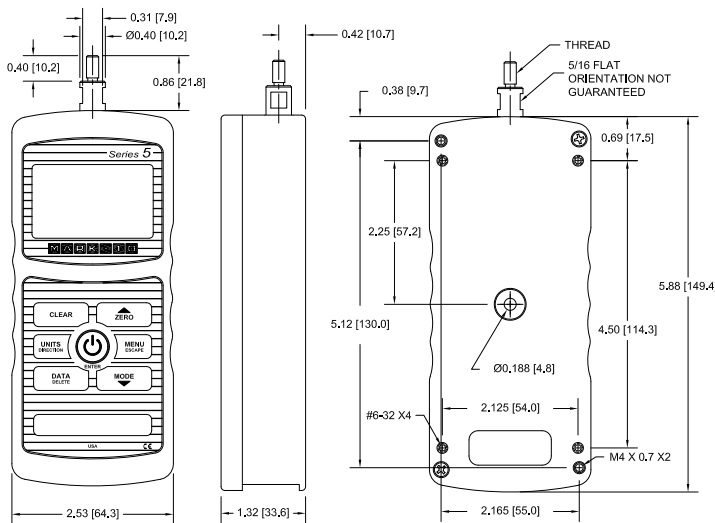

	Thread
M5-012 - M5-100	#10-32 UNF
M5-200 - M5-500	5/16-18 UNC

### Series 5 Model M5-1000

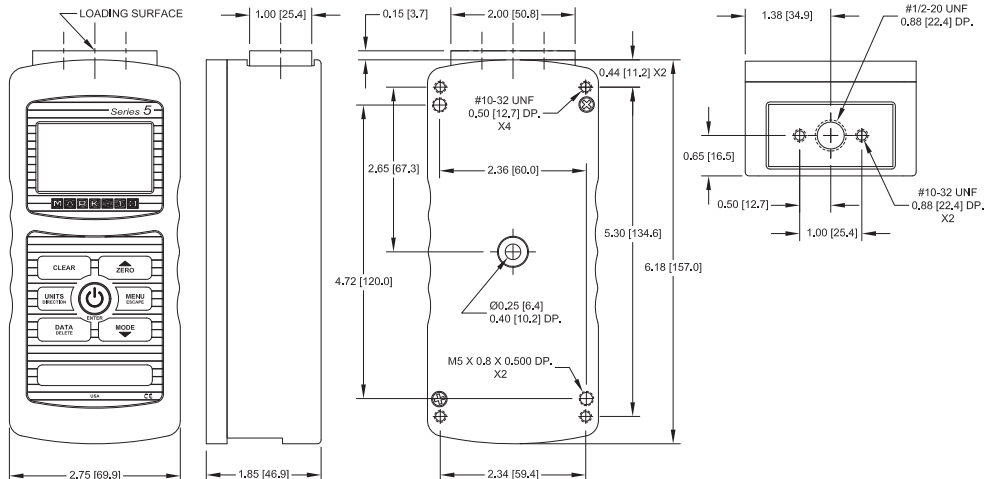

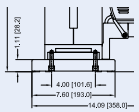

# Dimensional Drawings (in[mm])

## Force and torque gauges

### Series 4

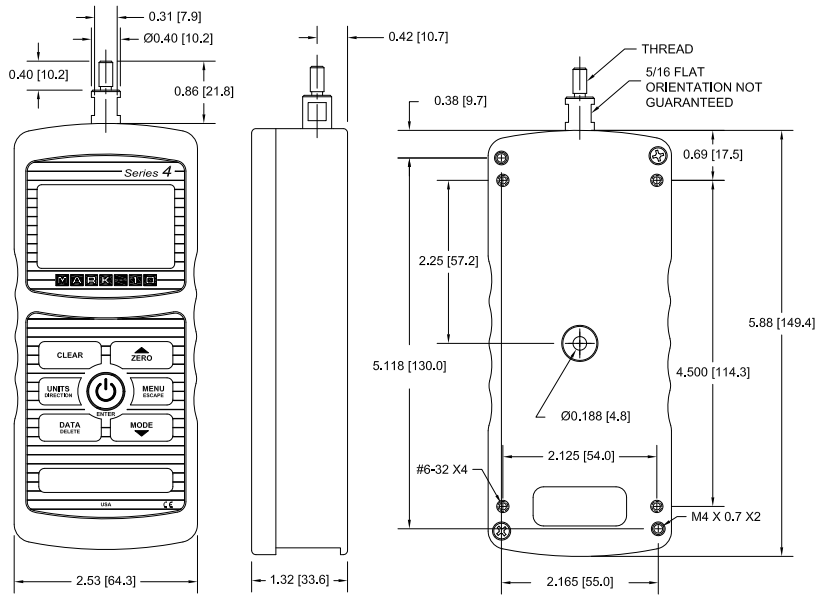

	Thread
M4-012 - M4-100	#10-32 UNF
M4-200 - M4-500	5/16-18 UNC

### Series 3

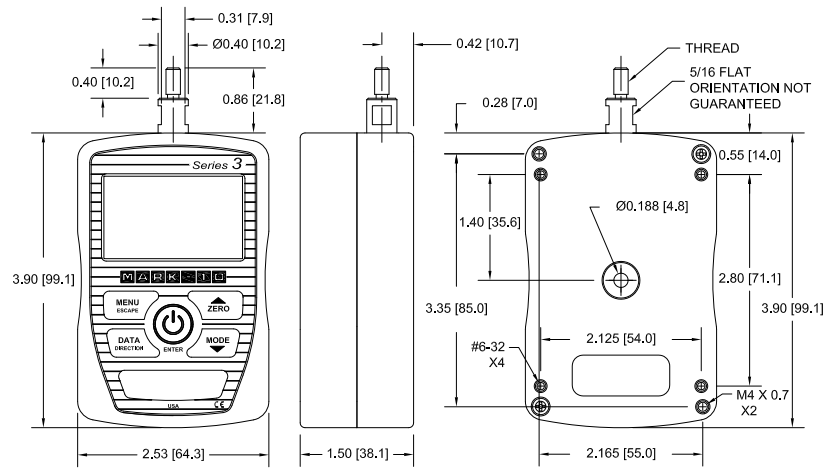

	Thread
M3-012 - M3-100	#10-32 UNF
M3-200 - M3-500	5/16-18 UNC

### Series 2

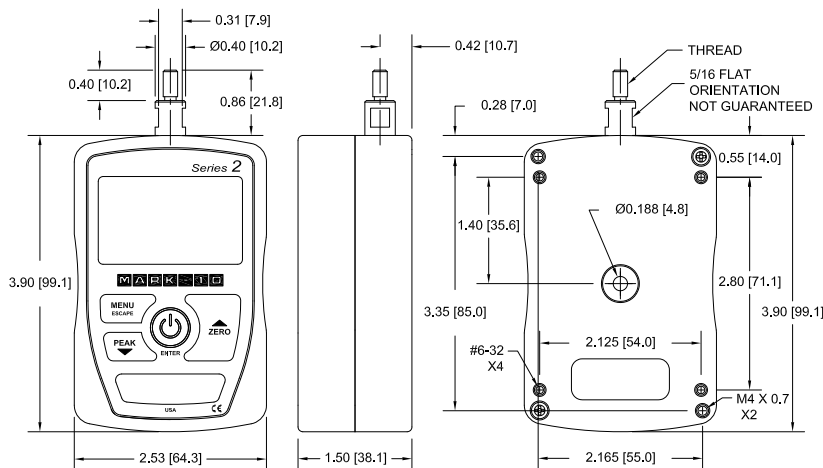

	Thread
M2-2 - M2-100	#10-32 UNF
M2-200 - M2-500	5/16-18 UNC

# Dimensional Drawings (in[mm])

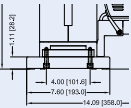

## Torque gauges and testers

### Series TT03

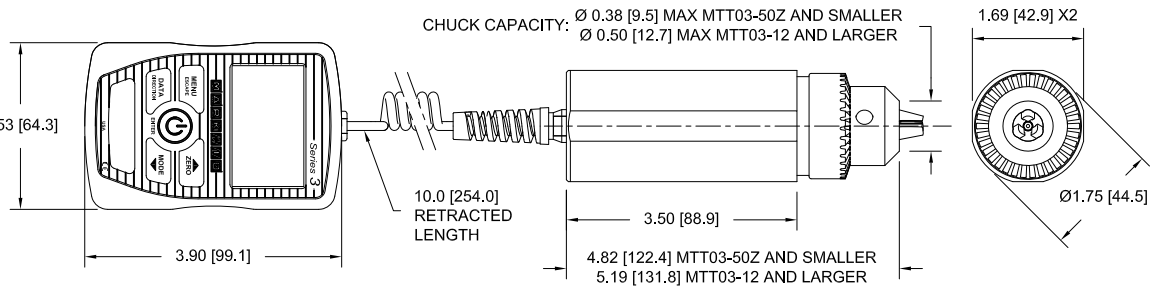

### Series TT01

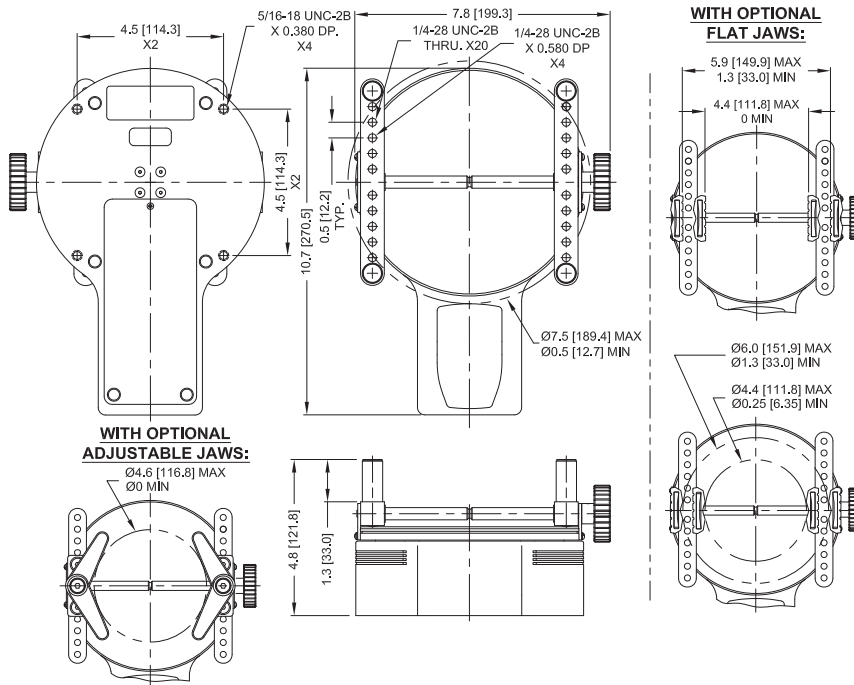

### Series TT05

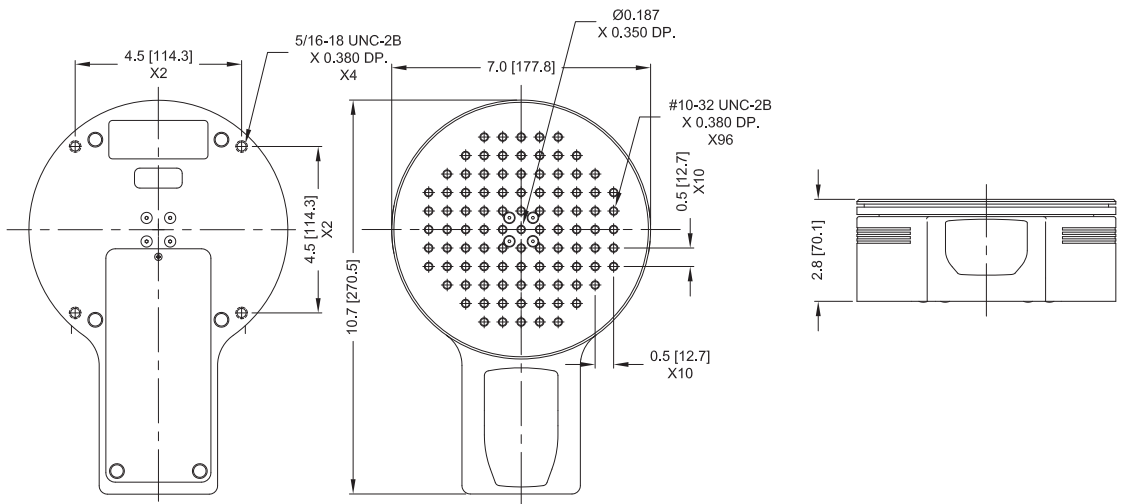

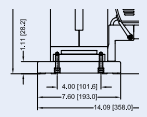

# Dimensional Drawings (in[mm])

## Torque testers

Series TT02

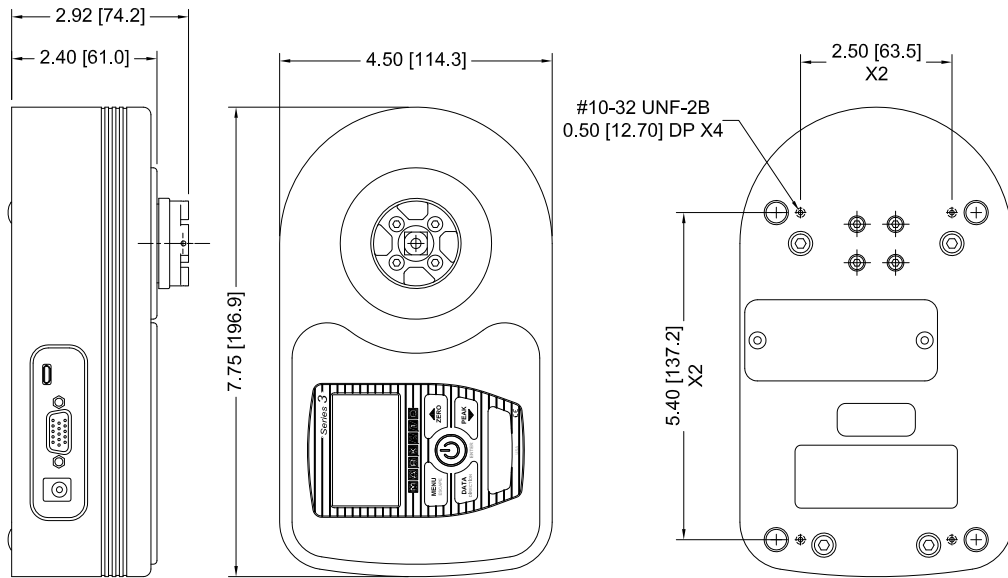

### RECEPTACLE TOP VIEW:

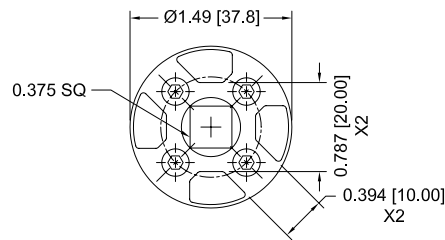



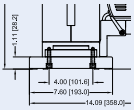

## Wire crimp pull testers

WT3-201

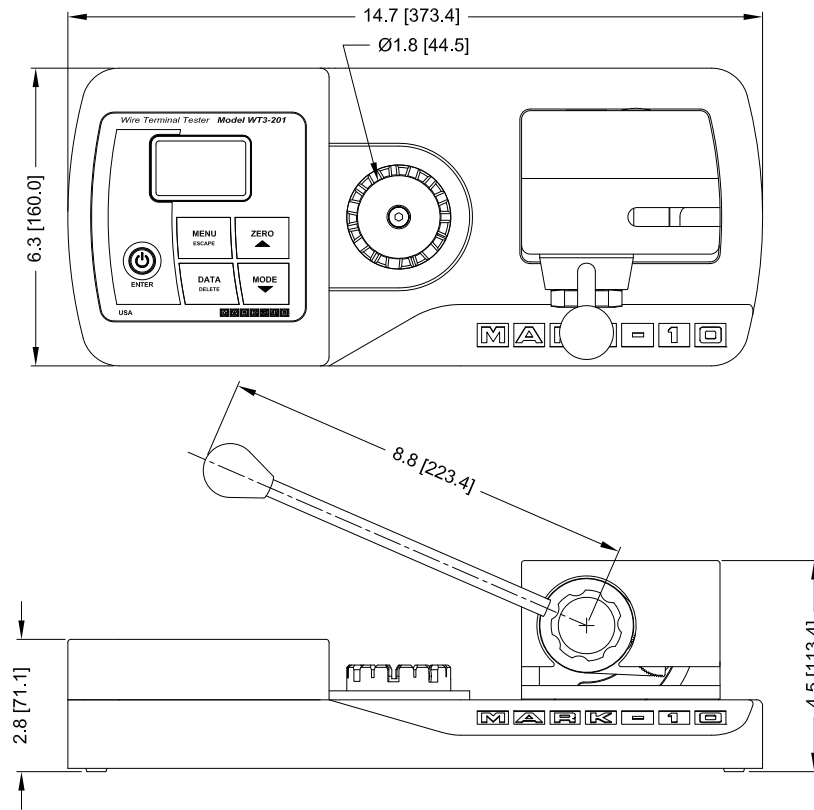

WT3-201M

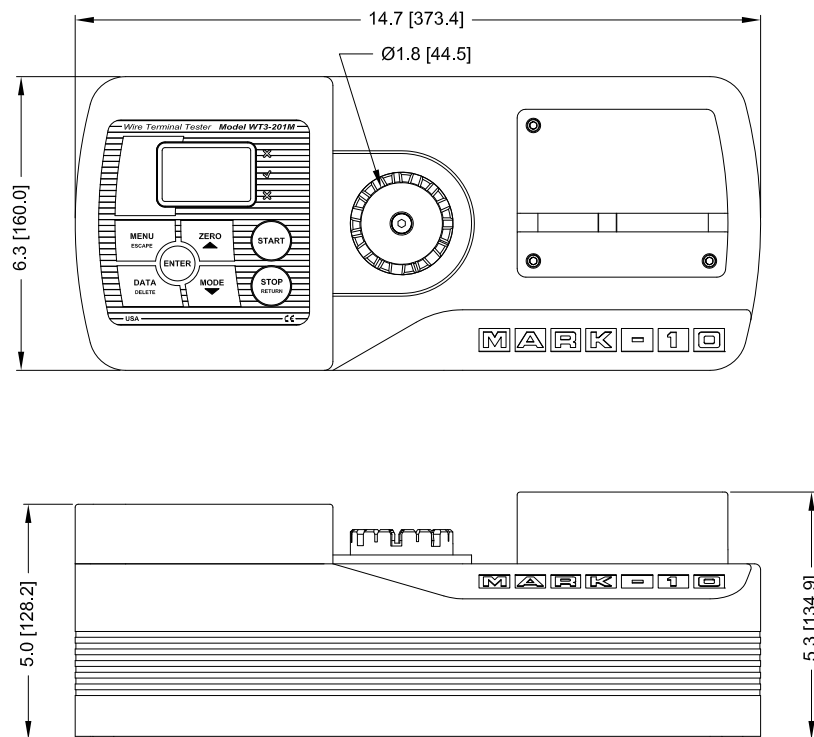

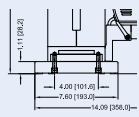

# Dimensional Drawings (in[mm])

## Force / torque indicators

Model 7i

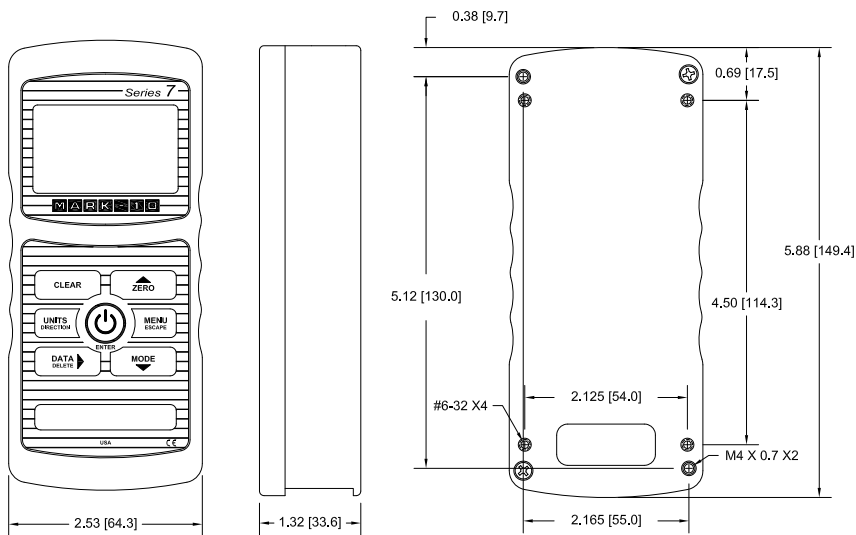

Model 5i

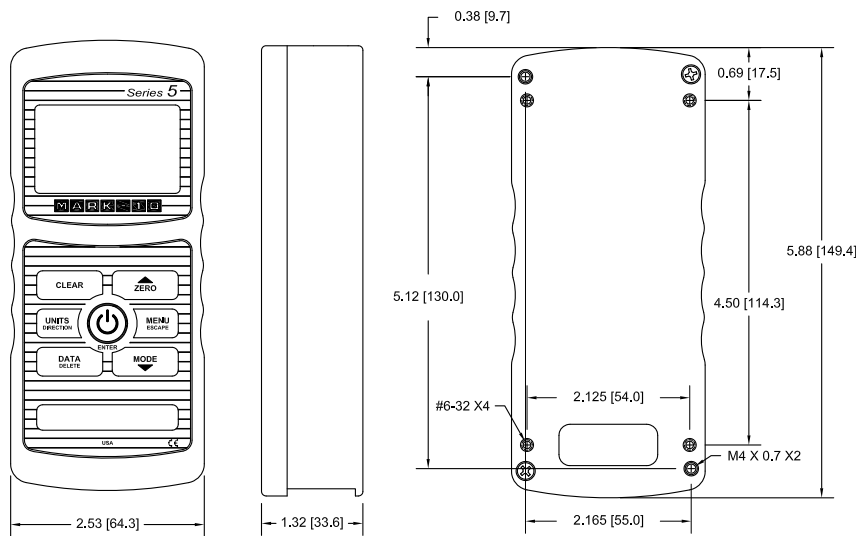

Model 3i

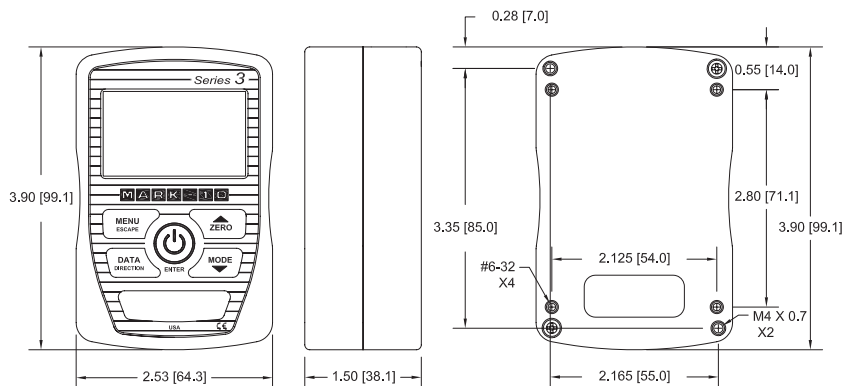

# Dimensional Drawings (in[mm])

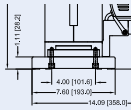

## Plug & Test™ sensors

### Series R50

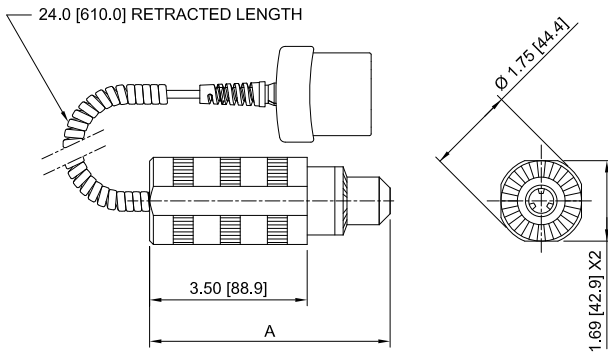

Model No.	A	Chuck Capacity
MR50-10Z - MR50-50Z	4.82 [122.4]	0.375 [9.5]
MR50-12 - MR50-100	5.19 [131.8]	0.5 [12.7]

### Series R51

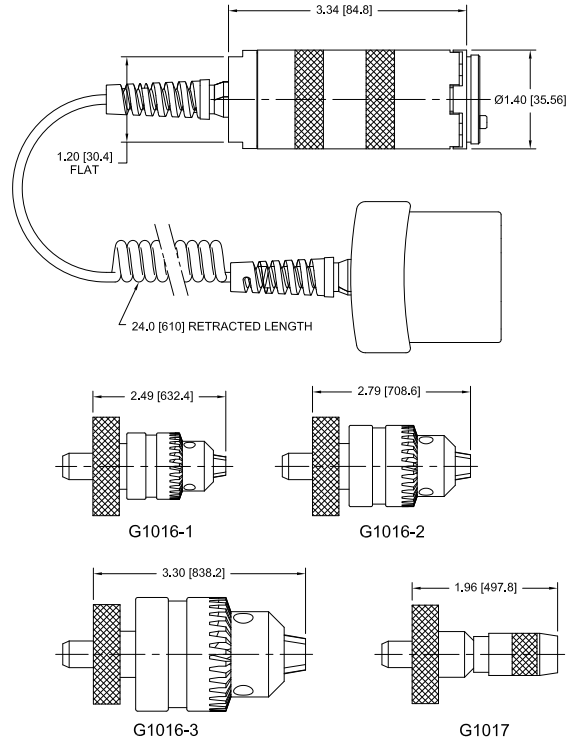

### Series R52

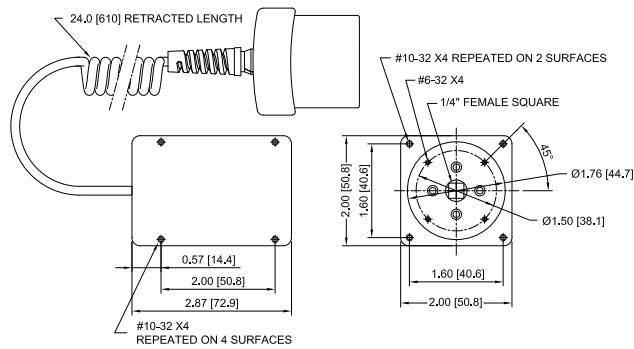

### Series R55

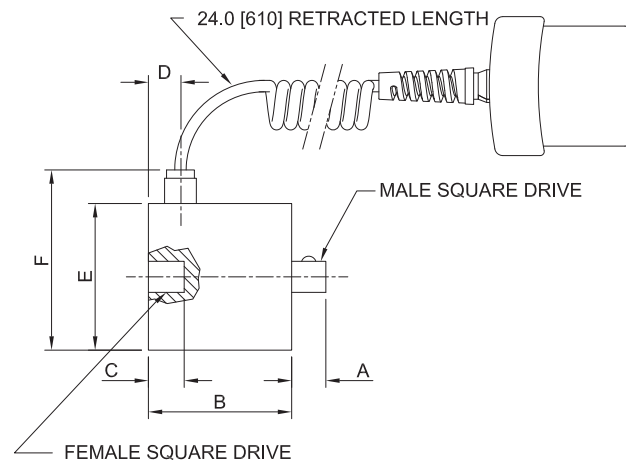

Model No.	Drive Size	A	B	C	D	ØE	F
MR55-20 - MR55-100	1/4"	0.30 [7.5]	1.73 [44.0]	0.32 [8.0]			
MR55-200 - MR55-400	3/8"	0.41 [10.5]	1.73 [44.0]	0.43 [11.0]	0.39 [10.0]	1.77 [45.0]	2.32 [59.0]
MR55-1000	1/2"	0.59 [15.0]		0.63 [16.0]			
MR55-5000	3/4"	0.89 [22.5]	2.11 [53.5]	0.94 [24.0]	0.77 [19.5]	2.01 [51.0]	2.56 [65.0]

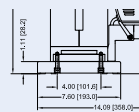

# Dimensional Drawings (in[mm])

## Plug & Test™ sensors

### Series R53 - Models MR53-12 - MR53-100

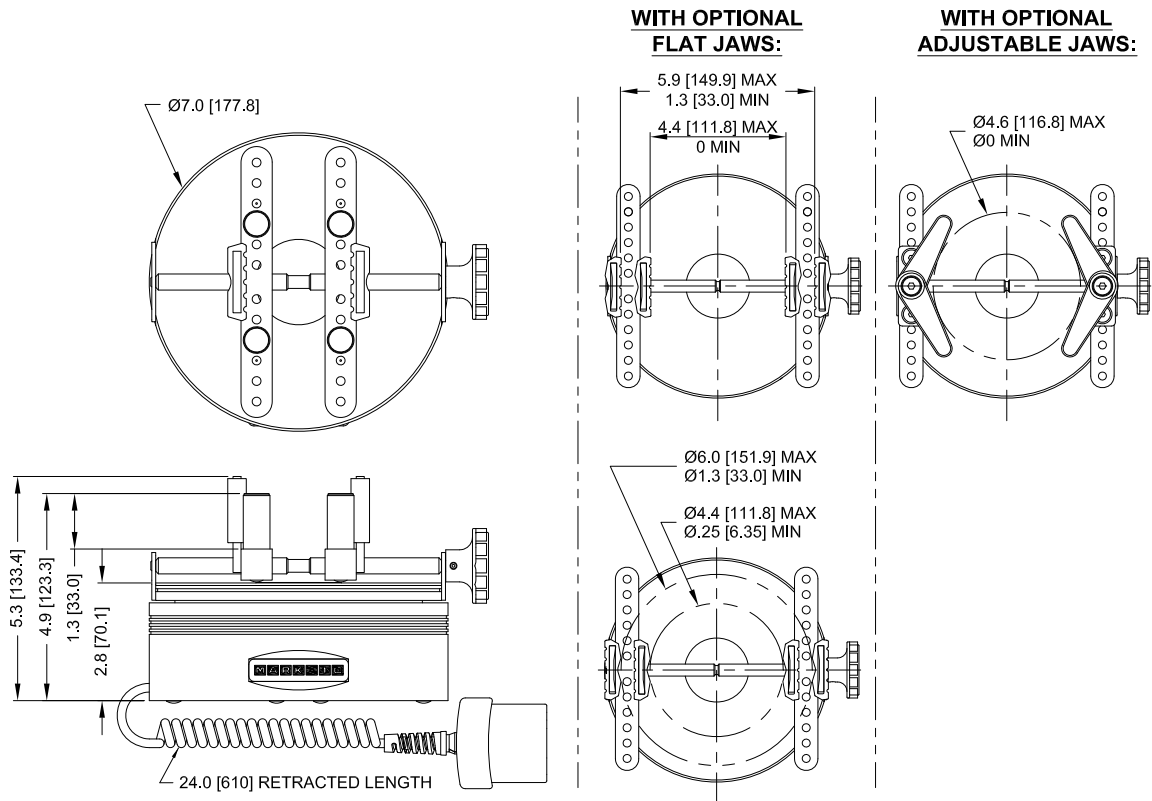

### Series R53 - Models MR53-10Z - MR53-50Z

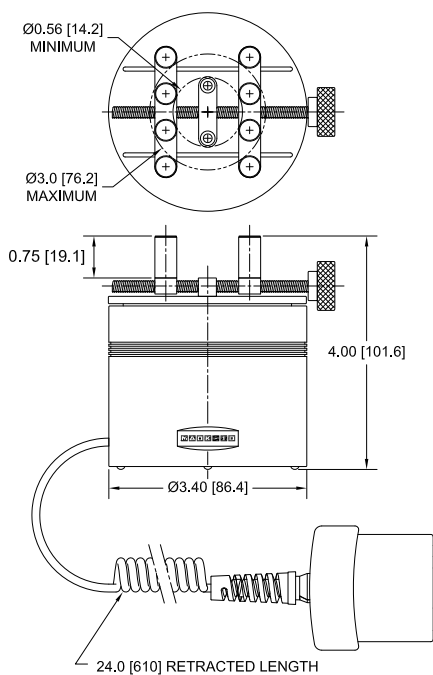

### Series R01

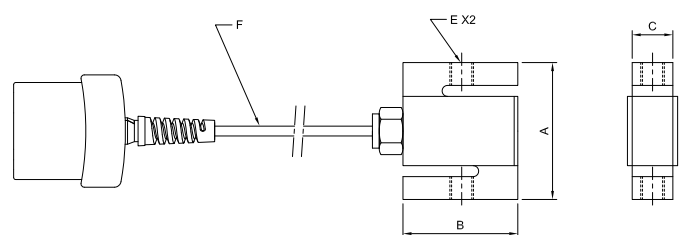

Model	A	B	C	E	F
MR01-50	2.40 [61.0]	2.00 [50.8]	0.46 [11.7]	1/4-28 UNF	MR01-XXXX: 20 ft [6 m]  MR01-XXXX-1* 10 in [254 mm]*
MR01-100					
MR01-200					
MR01-500					
MR01-1000	0.71 [18.0]	1/2-20 UNF			
MR01-2000					
MR01-5000	3.90 [99.1]	3.00 [76.2]	0.96 [24.4]	3/4-16 UNF	
MR01-10000					

\* Add suffix "-1" for shortened cable, for use on the ESM1500LC and ESM303(H) test stands.  
Ex: MR01-1000-1. Test stand mounting hardware is included.

# Dimensional Drawings (in[mm])

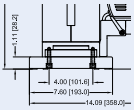

## Plug & Test™ sensors

### Series R02

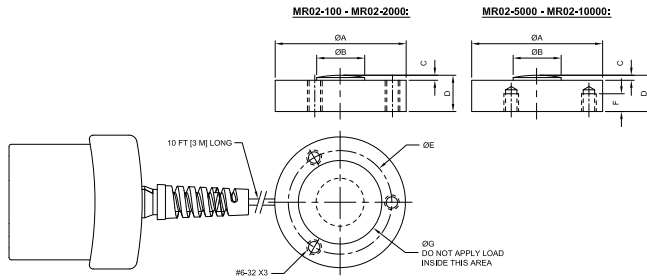

Model	ØA	ØB	C	D	ØE	F	ØG
MR02-100 - MR02-2000	1.23 [31.3]	0.32 [8.1]	0.05 [1.3]	0.39 [9.9]	1.0 [25.4]	THRU	0.83 [21.1]
MR02-5000 - MR02-10000	1.48 [37.6]	0.43 [10.9]	0.07 [1.8]	0.62 [15.8]	1.25 [31.8]	0.25 [6.4]	1.08 [27.4]

### Series R03

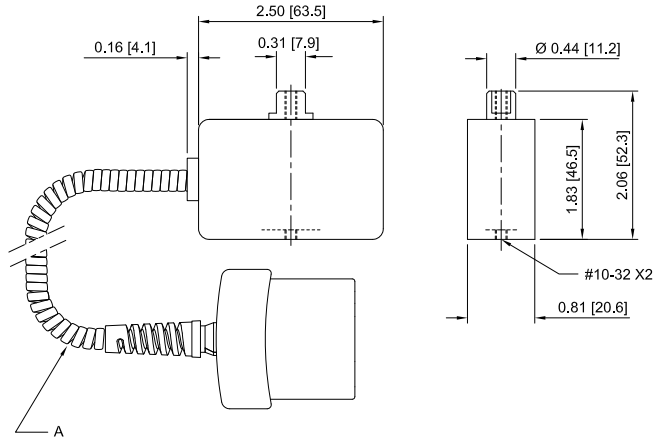

Model No.	A
MR03-XXX	20 ft [6 m], coiled, retracted
MR03-XXX-1*	10 in [254 mm], straight*

\* Add suffix "-1" for shortened cable, for use on the ESM1500LC and ESM303(H) test stands.  
Ex: MR03-50-1. Test stand mounting hardware is included.

### Series R04

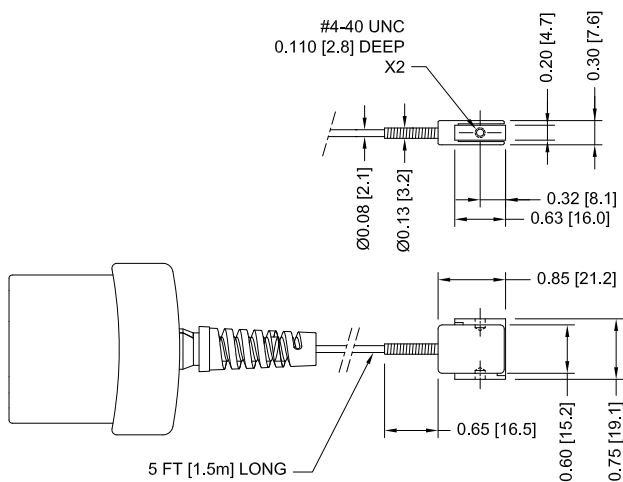

### Series R05

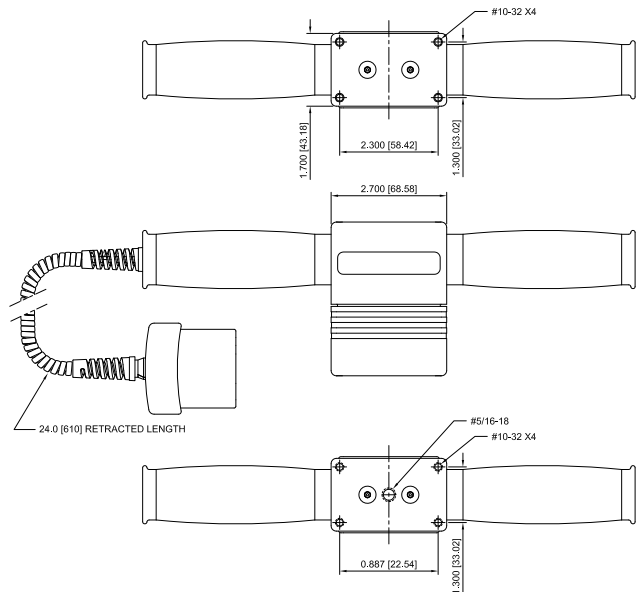



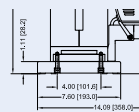

# Dimensional Drawings (in[mm])

## Test stands

### Model ES05

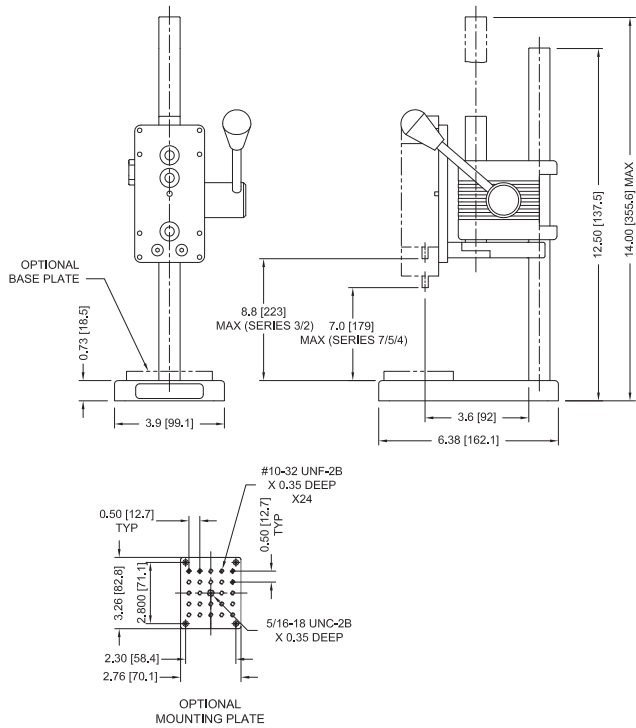

### Model ES10

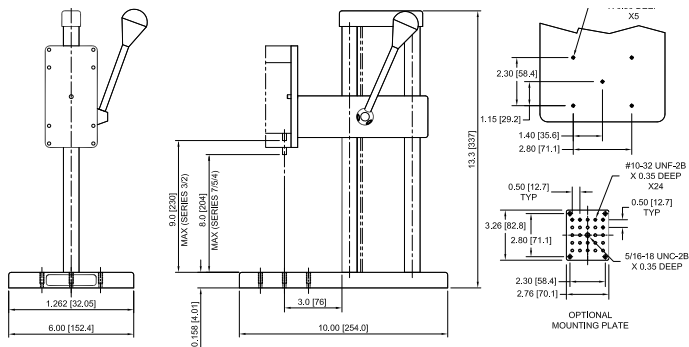

### Model ES20

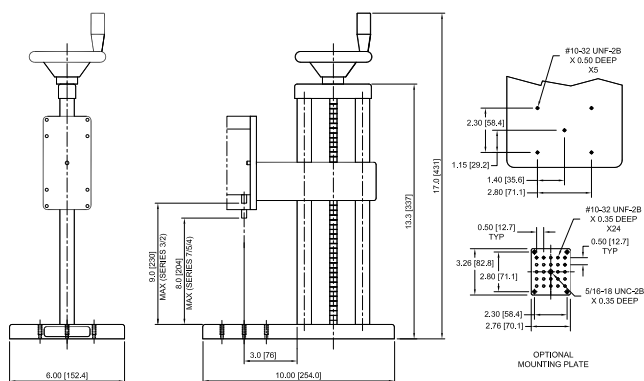

### Model ES30

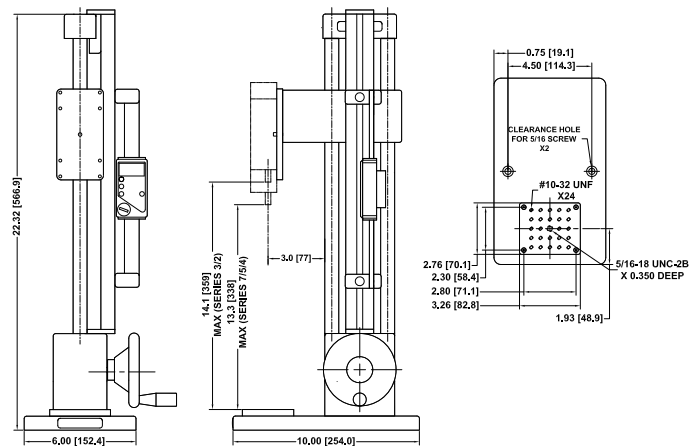

# Dimensional Drawings (in[mm])

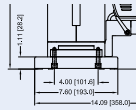

## Test stands

### Model ESM303

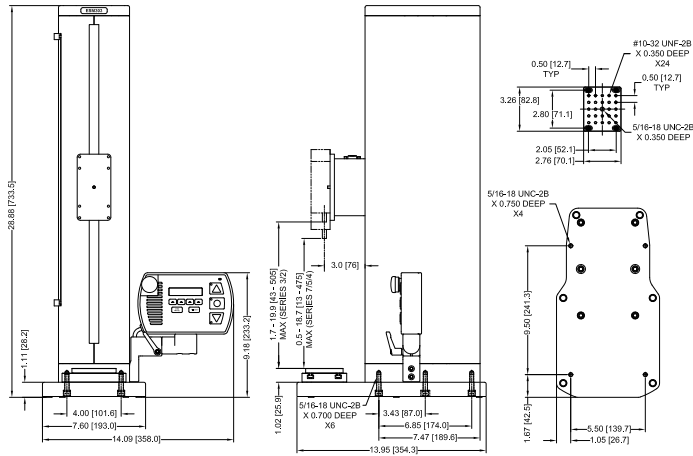

### ESM1500LC

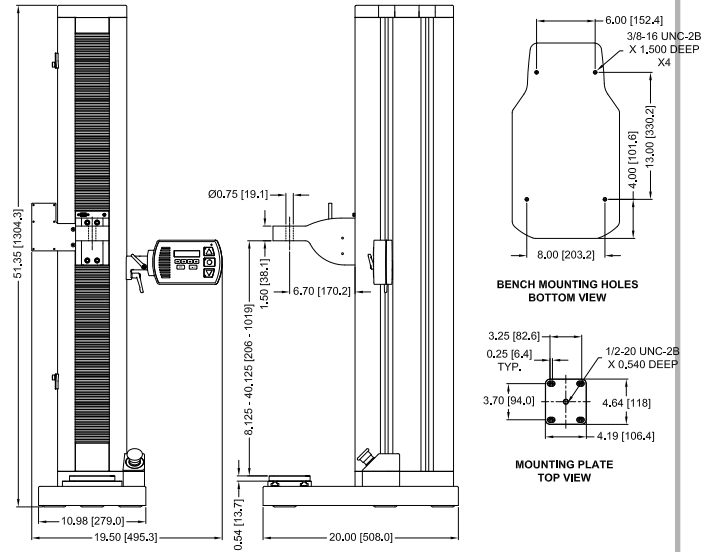

### ESM1500FG

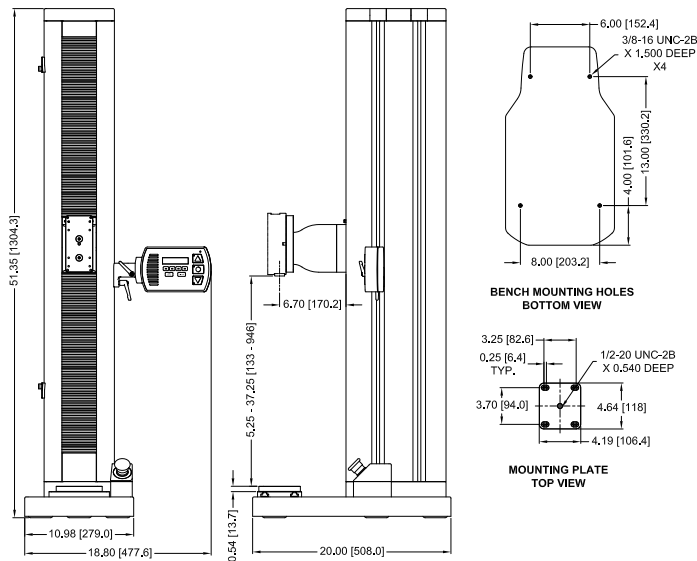

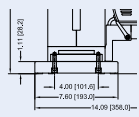

# Dimensional Drawings (in[mm])

## Test stands

### Model TSA750H

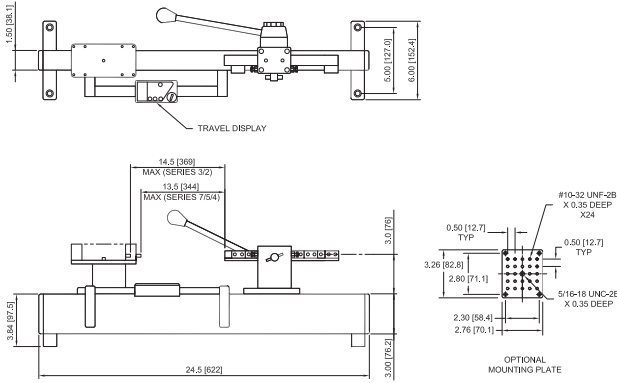

### Model TSB100

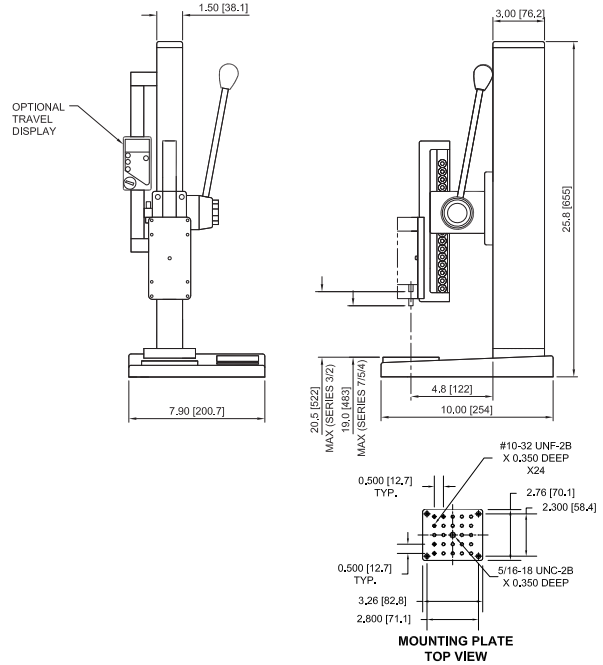

### Model TSC1000

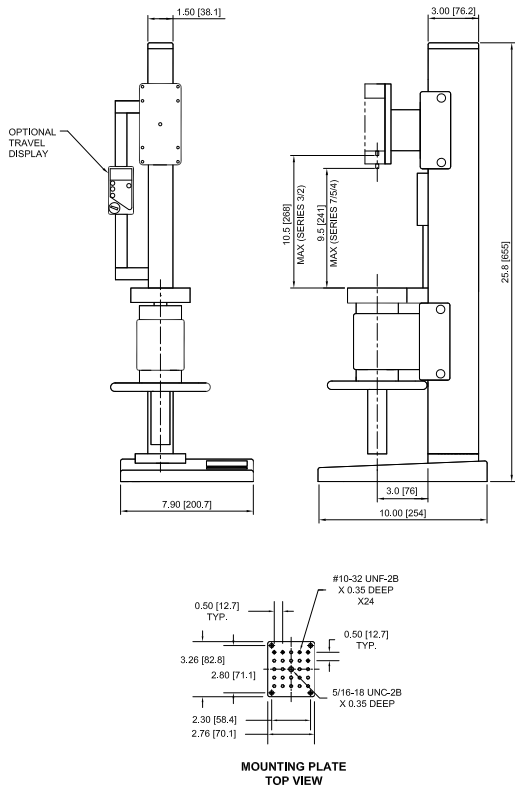

### Model TSC1000H

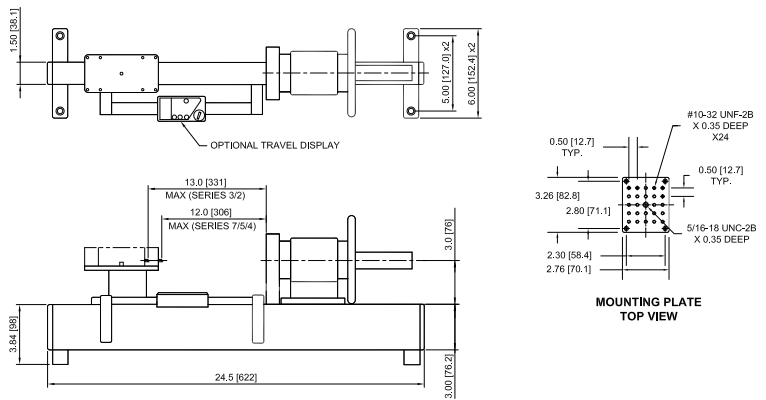

# Dimensional Drawings (in[mm])

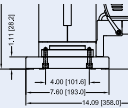

## Test stands

### Model TSF

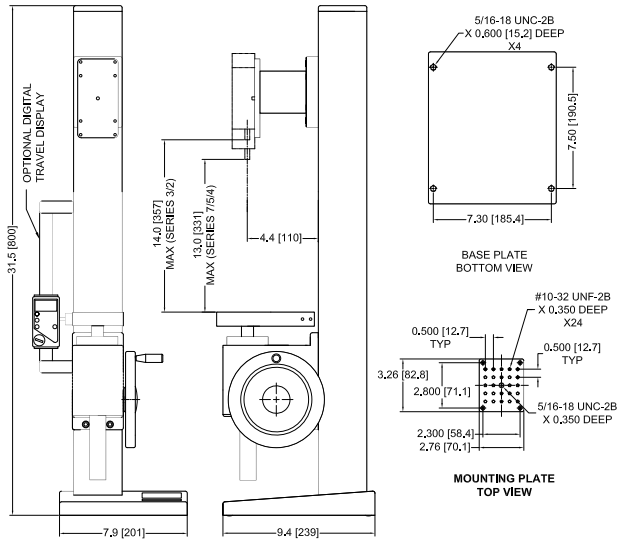

### Model TSFH

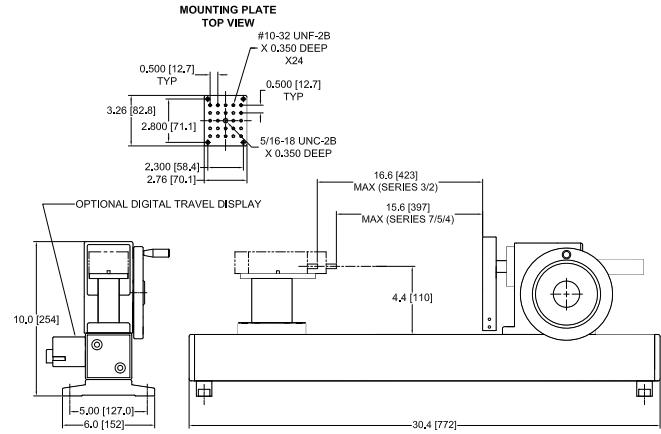

### Model TSFM500

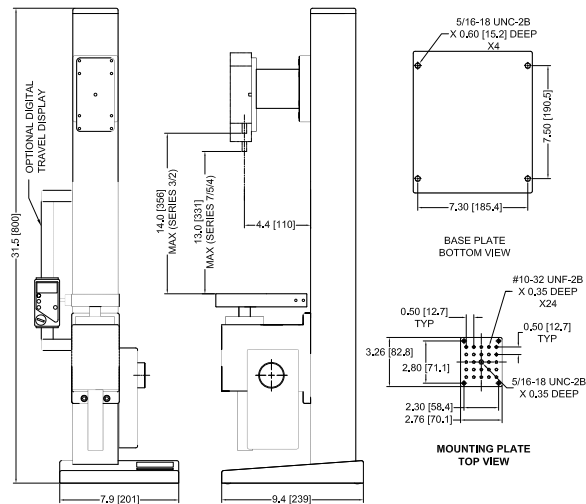

### Model TSFM500H

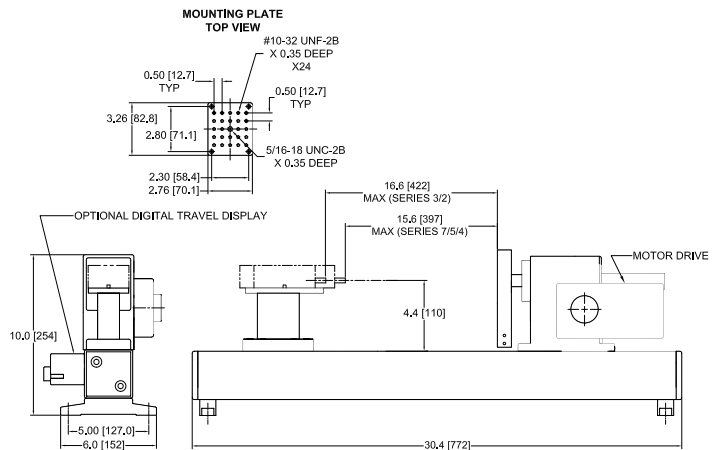

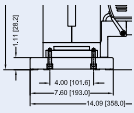

# Dimensional Drawings (in[mm])

## Test stands

### Model TST

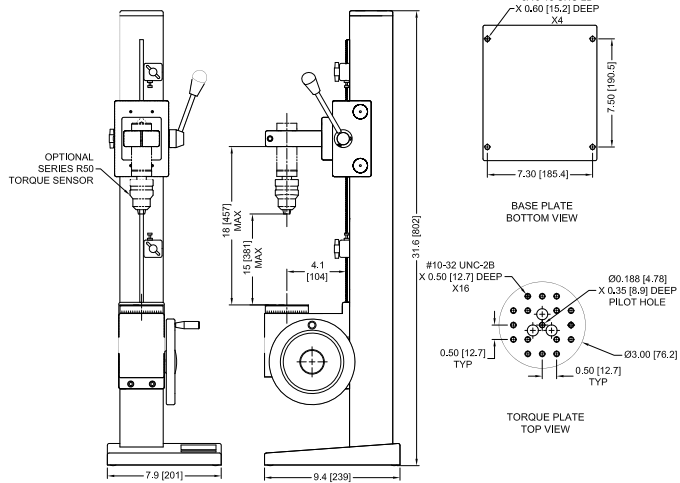

### Model TSTH

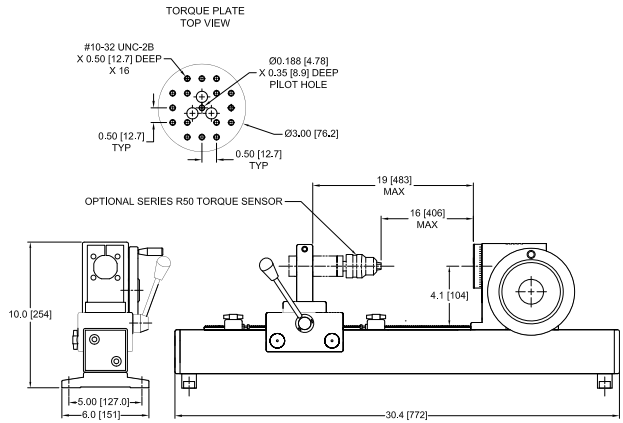

### Model TSTM

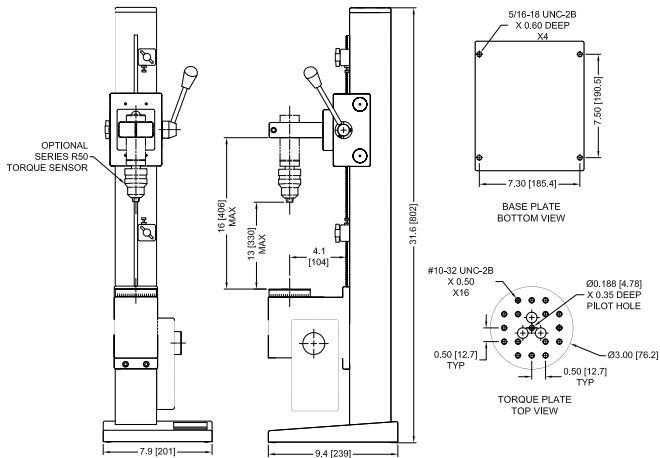

### Model TSTMH

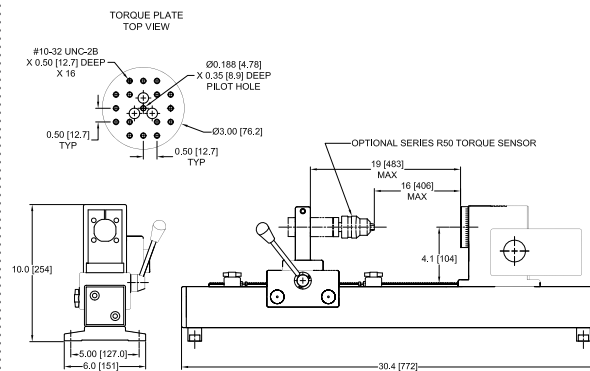

### Series DC Controllers

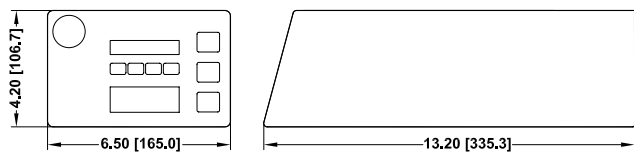

### Model TSA750

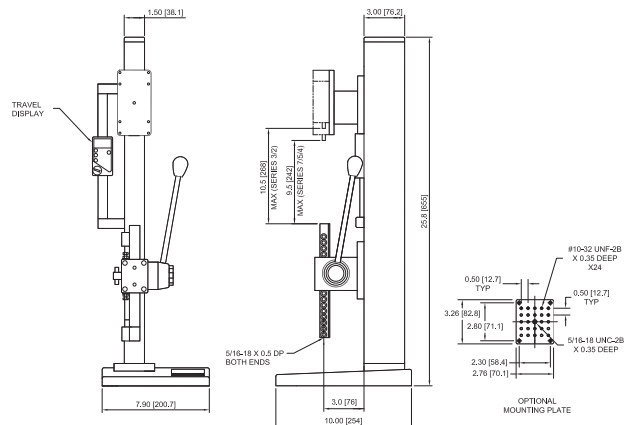



# Notes

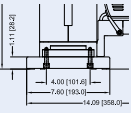

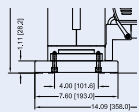

# Notes

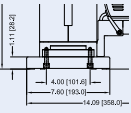

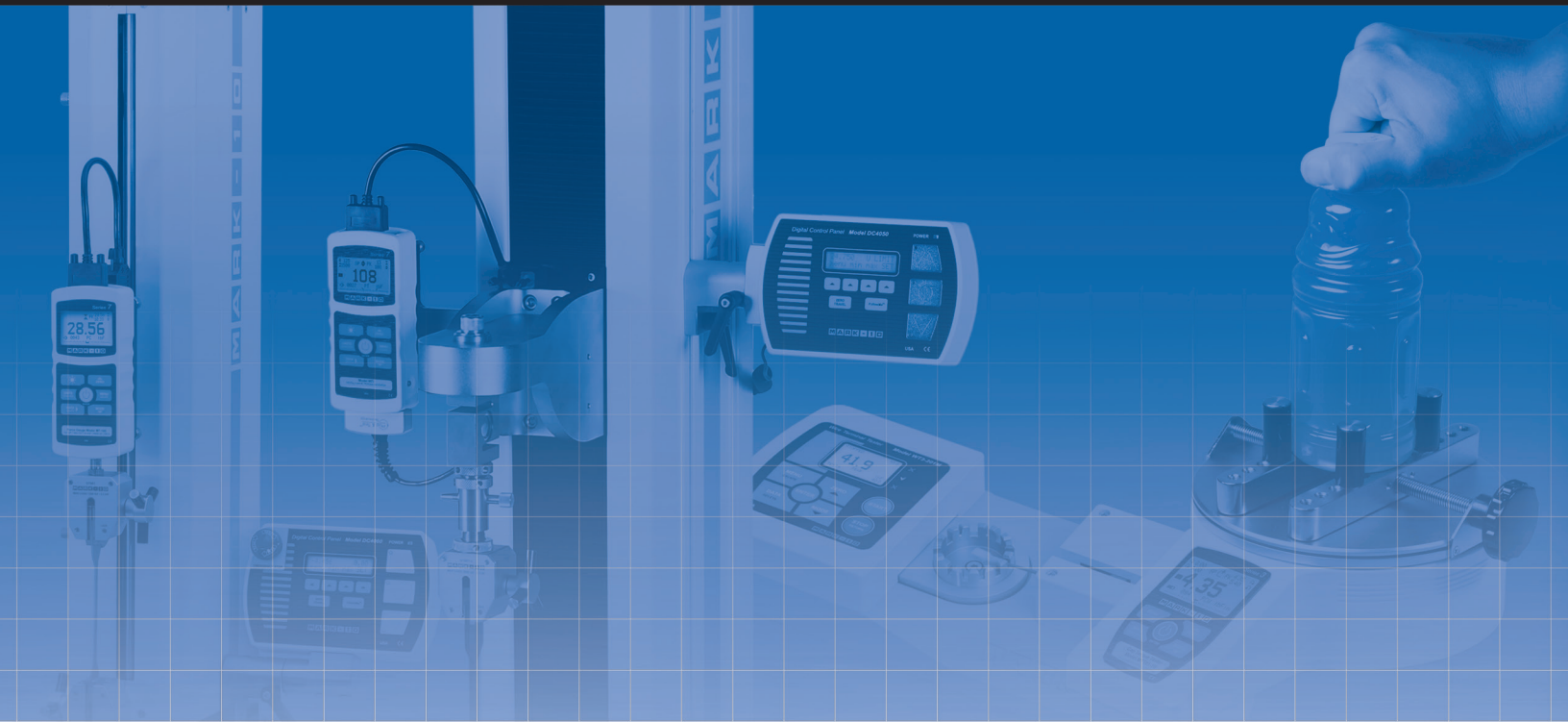

## Applications are virtually limitless...

Mark-10 force and torque measurement products help quality control, engineering, and manufacturing professionals assess and ensure quality in virtually every industry worldwide.

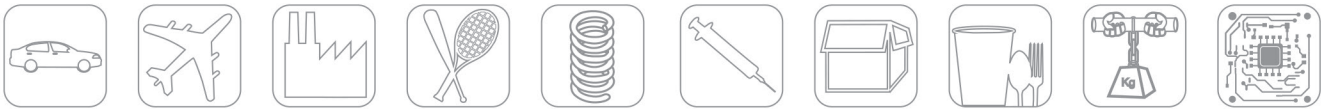

# MARK-10

Force and Torque Measurement Engineered Better

Mark-10 Corporation  
11 Dixon Avenue ■ Copiague, NY 11726 USA  
888-MARK-TEN ■ Tel: +1 631 842 9200 ■ Fax: +1 631 842 9201  
www.mark-10.com ■ info@mark-10.com



© 2016 MARK-10 CORPORATION  
32-1000