



**SNAP** DM 200

# SWAP

Family of Products



**Total Quality  
Systems Inc.**

1783 W. University #135  
Tempe, AZ 85281  
E-Mail [sales@tqscorp.com](mailto:sales@tqscorp.com)

Inside Sales/Office 480-377-6422  
Fax 480-377-6426  
Todd direct 602-228-3863



**SNAP**

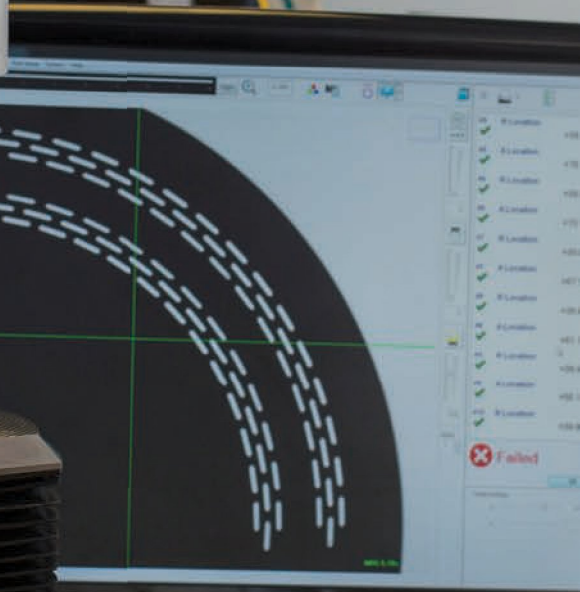
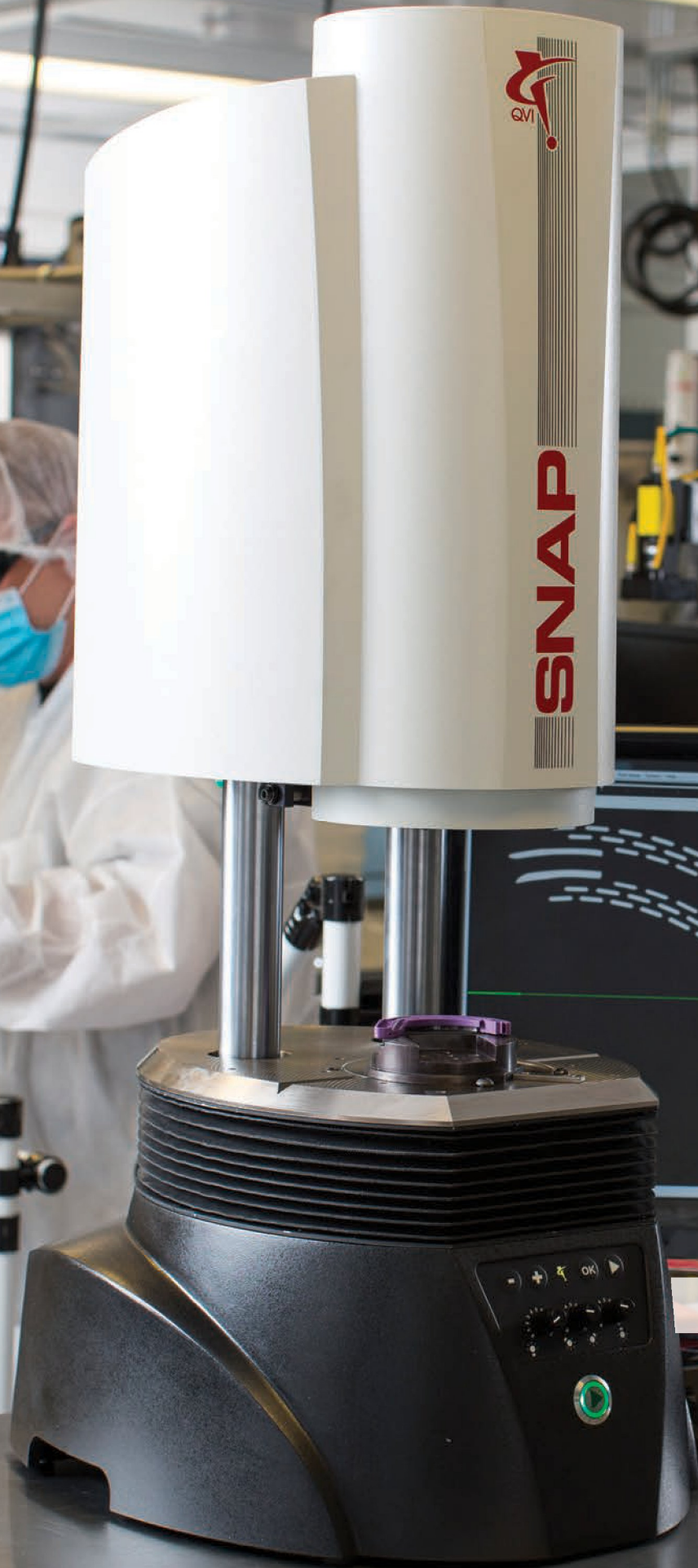

**SNAP**

# The New Way to Measure Small Parts

QVI® SNAP™ measurement systems are designed to measure small, intricate parts right on the manufacturing floor.

**SNAP** combines a high resolution digital metrology camera with specially designed optics and lighting to produce high accuracy images, even in shop-floor conditions.

**SNAP DM200** extends measuring range with a precision motorized X-axis stage, and the flexibility of two built-in optical magnifications.

All SNAP systems are simple to use. With automatic part ID and AutoCorrelate, simply place a part on the SNAP and press GO. Single parts, multiple parts – even a mixture of different parts – are all measured automatically.

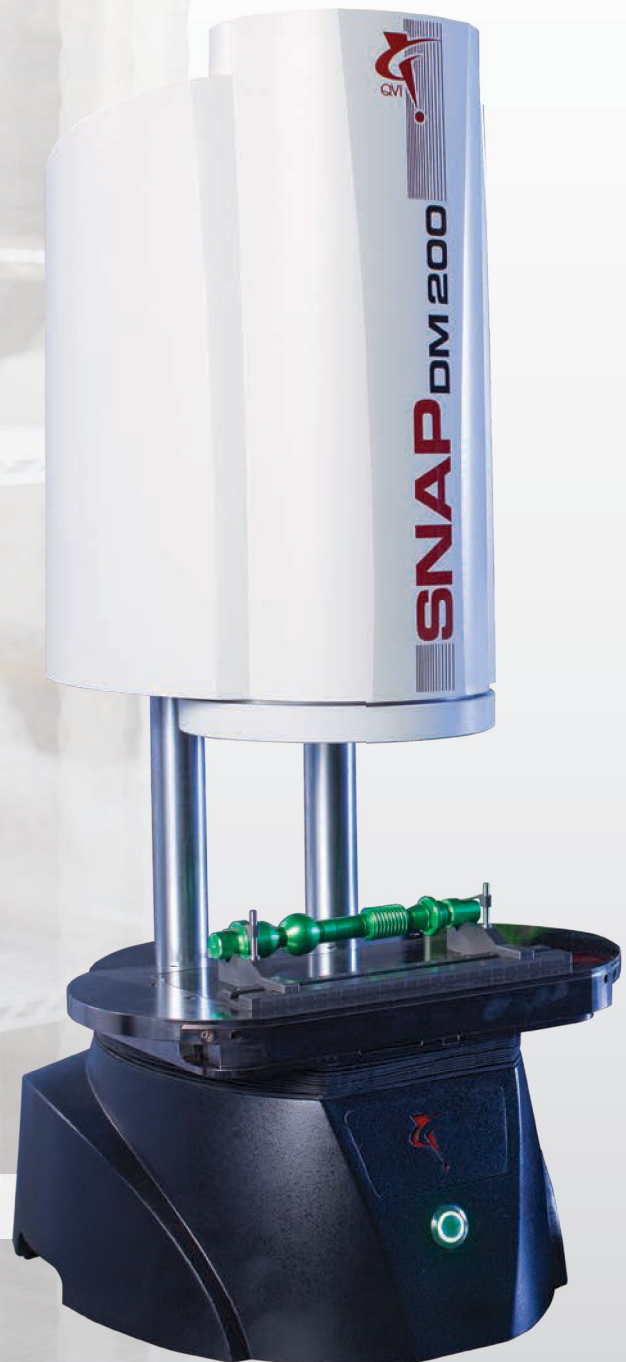

SNAP DM200

**SNAP DM 20**

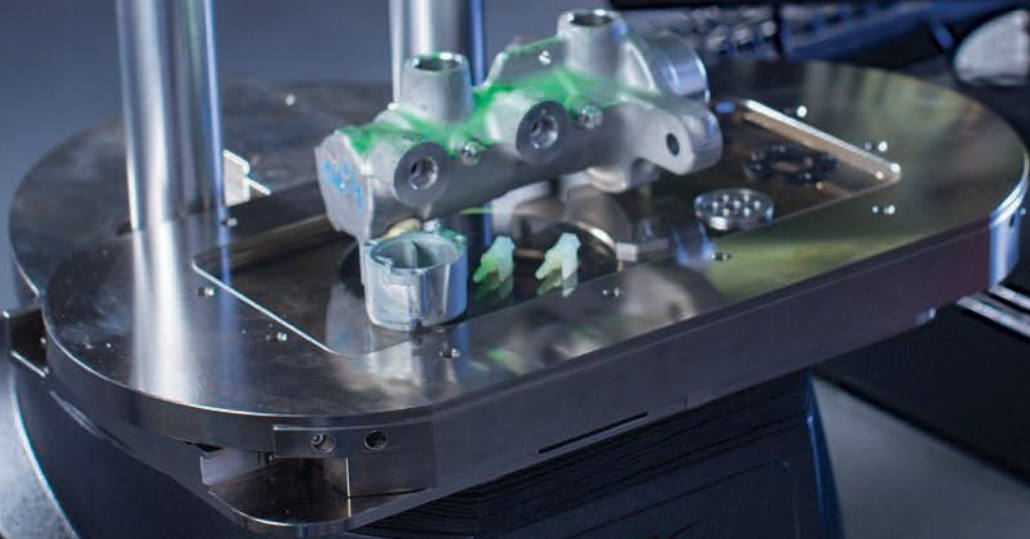
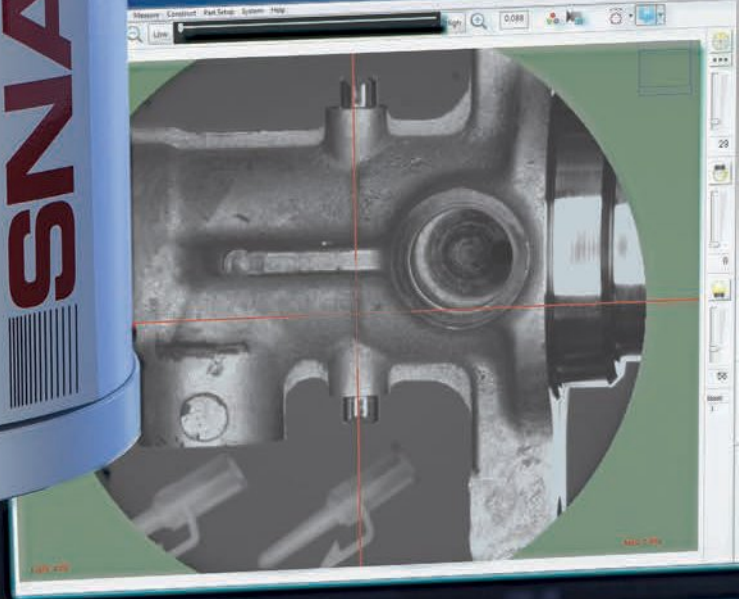



# A Versatile Digital Measuring Machine

SNAP is designed to measure anywhere – from the shop floor to the lab, or as part of an automated work cell. Rugged construction and an open work envelope make SNAP easy to implement in virtually any manufacturing setting.

SNAP's unique optics and capable software allow measurement of a wide range of parts – from connectors to castings.

SNAP DM200's precision X-axis stage allows measurement of parts up to 250 mm in length. Built-in image stitching combines multiple snapshots into a single image for part location and identification.



## Lab Inspection

Secure software and easy on-site calibration make SNAP the ideal solution for FDA-compliant manufacturing operations.



## Shop-Floor Hardened

SNAP systems are built to handle temperature and vibration extremes on the shop floor.

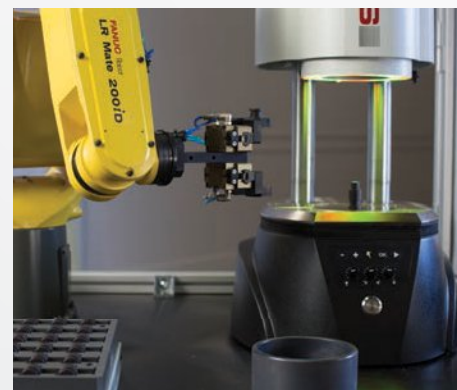

## Automation

SNAP systems have an open work envelope that makes it easy to load and unload parts manually or within a robotic work cell.

# Select The System That Fits Your Needs

SNAP is offered in three configurations to suit a wide range of measurement needs.

SNAP offers a 75 mm (3 inch) diagonal by 75 mm deep measuring envelope. Its high density camera with exclusive Zoom Anywhere™ technology allows you to zoom in for a closer look at fine details.

SNAP DM200 combines a 100 mm (4 inch) circular by 75 mm deep measuring envelope with a 150 mm moving stage, allowing measurement of parts up to 250 mm in length. Motorized autofocus, exclusive Zoom Anywhere™ technology and a selectable high magnification lens increase optical precision for measuring very small features.

SNAP DM200 is also available with an optional high density camera providing added resolution for ultra-fine feature measurements.



## Simple Controls

SNAP systems have a logical control panel with oversized light control knobs and a simple program start GO button.

All controls for SNAP are located on the machine base while SNAP DM200 system controls are integrated into a rugged enclosure which can be located in any convenient position near or under the measuring system.



## Compact Footprint

SNAP is a compact benchtop system that can be used virtually anywhere.

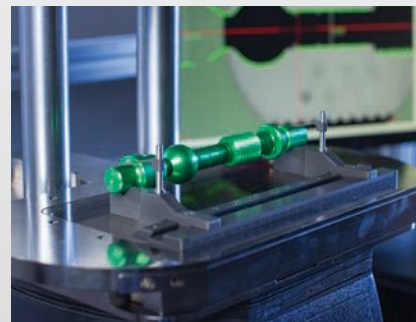

## Precision Motorized Stage

SNAP DM200 has a motorized stage for measuring parts that do not fit entirely within its 100 mm field of view.



## SNAP

	Standard	Optional
<b>Field of View</b>	75 mm diagonal	
<b>Optics</b>	Fully telecentric, fixed lens	
<b>Camera</b>	QVI® digital five megapixel, black and white	
<b>Depth of Field</b>	Low Mag: 38 mm High Mag: 4.75 mm	
<b>Worktable</b>	10 Kg load capacity, evenly distributed, 75 mm manual vertical (Z) position adjustment	- Motorized vertical position adjustment - 2-position shuttle stage - Rotary indexer
<b>Accuracy</b>	Low Mag	High Mag
	10 µm + L/150	5 µm + L/150

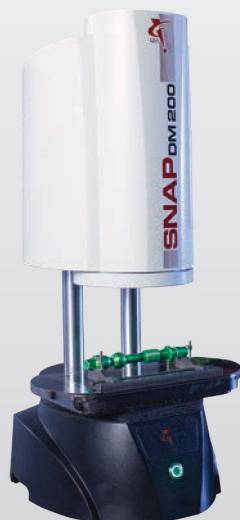

## SNAP DM200

	Standard	Optional
<b>Stage Motion</b>	X: 150 mm Z: 75 mm	
<b>Field of View</b>	Low Mag: 100 mm circular High Mag: 25 mm	Low Mag: 78 mm diagonal High Mag: 19.5 mm
<b>Optics</b>	Fully telecentric, dual magnification	
<b>Camera</b>	QVI® digital four megapixel, black and white	QVI® high density digital five megapixel, black and white
<b>Depth of Field</b>	Low Mag: 38 mm High Mag: 4 mm	
<b>Worktable</b>	10 Kg load capacity, evenly distributed, 75 mm motorized vertical (Z) position adjustment	- Rotary indexer
<b>Accuracy</b>	Low Mag	High Mag
	10 µm + L/150	5 µm + L/150

# Innovative Optics

The key to SNAP's versatility is its unique large-field-of-view optical system which lets you see and measure entire parts at once.

Creating a large area image with the precision for accurate measurements takes special care. SNAP's optics, illumination and camera are designed as a system to perform well in a wide range of situations.

## Low Distortion

Low distortion over the entire field is assured by careful design and manufacturing of each element in the lens system, and the rigid support structure provided by the cast aluminum base.

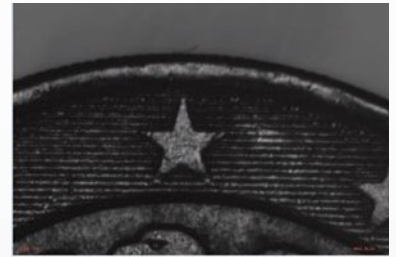

## Fully Telecentric Optics

Telecentric optics ensure that size measurements are accurate anywhere within the extended depth of field. Because many features in the measuring envelope are in focus at all times, most parts can be measured without special fixturing, and without the need to refocus for each part.

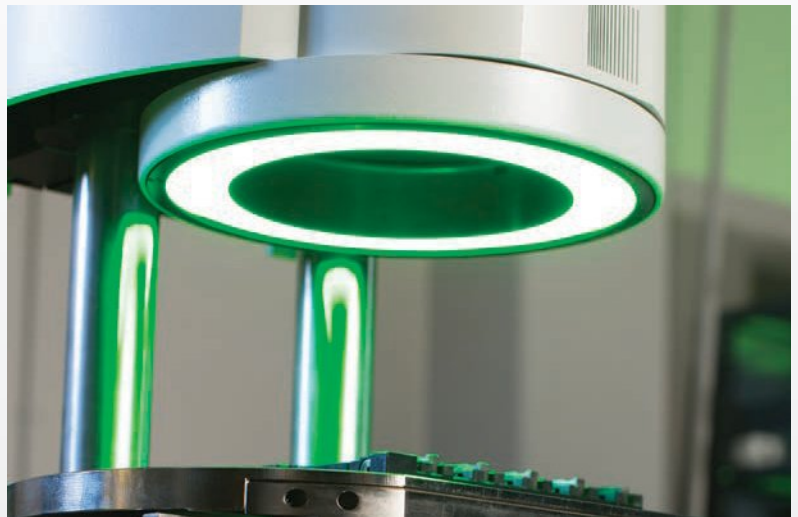

## Versatile Lighting

A collimated back light, straight-on high intensity surface light and a programmable multi-sector ring light let you measure details from every angle.

## Zoom Anywhere™

Digital image processing lets you pan and zoom in on any area of the image for a closer look. A range of zoom levels makes it easy to view small features and place tools to measure at exact locations. Zoom Anywhere™ is instantaneous, with no moving parts and no change in calibration.

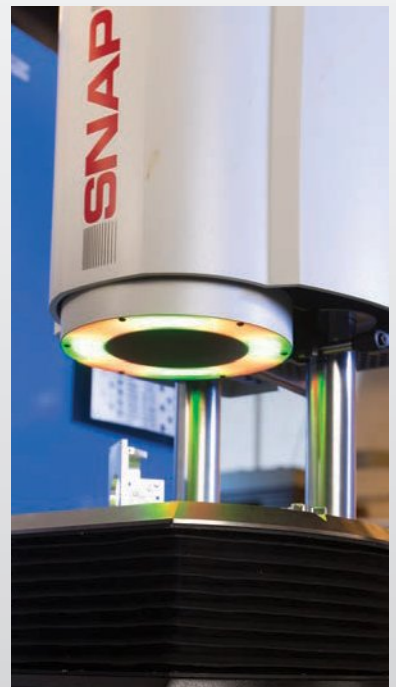
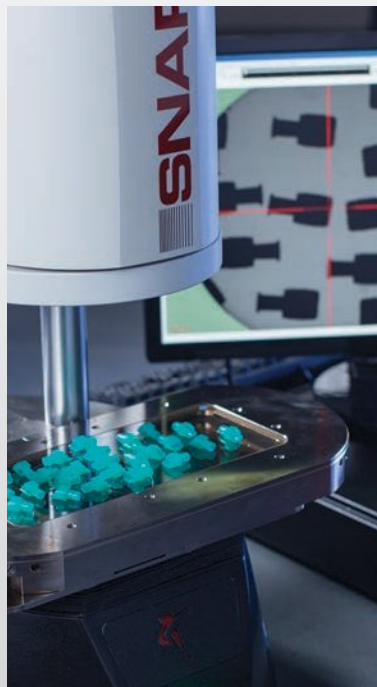

## Exclusive AccuCentric®

AccuCentric auto-calibration confirms optical calibration automatically each time the optical magnification is changed.



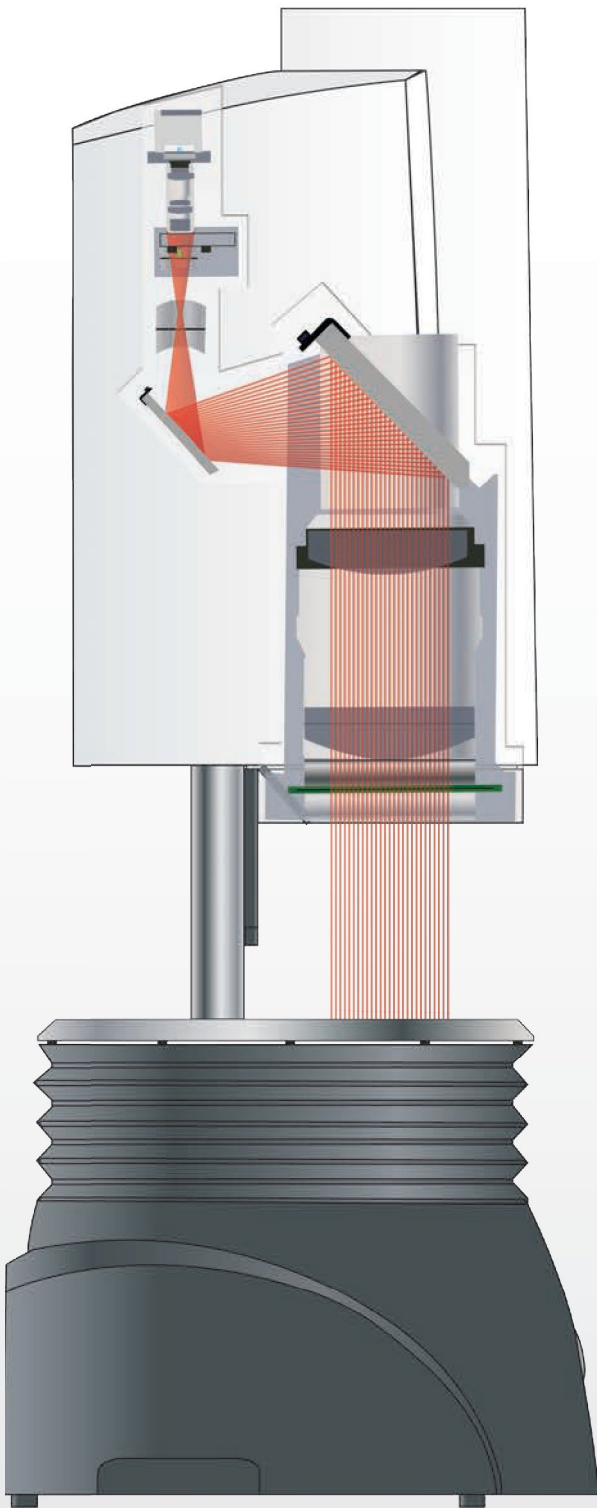

## SNAP

SNAP offers a measurement envelope that is 75 mm (3 inches) diagonally by 75 mm deep. Anything fitting within this volume can be measured quickly and accurately. SNAP features a high density camera and a multi-color ring light perfect for highlighting surface details.

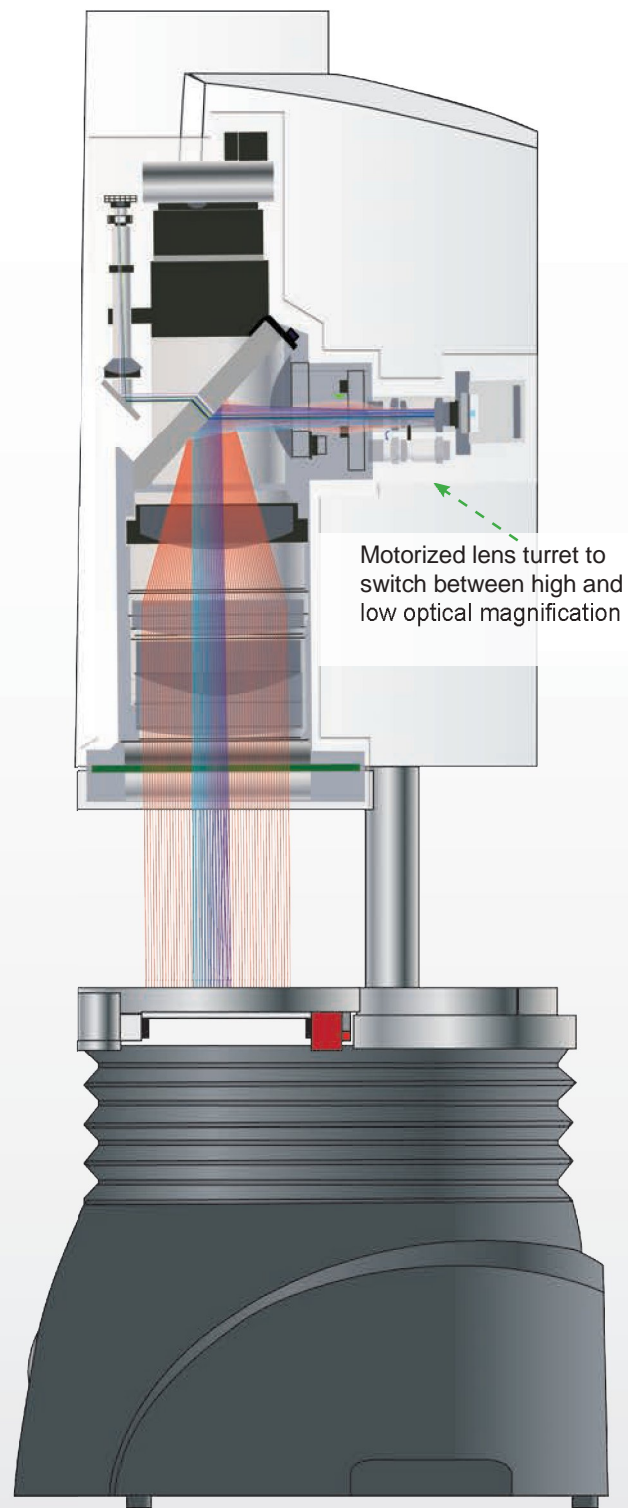

## SNAP DM200

SNAP DM200 extends measurement range with a 100 mm (4 inch) diameter field of view, and a precision 150 mm (6 inch) X-axis stage allowing parts up to 250 mm (10 inches) to be measured in a single routine. A high magnification objective lens allows the smallest features to be measured with confidence. Programmable motorized Z positioning and autofocus are standard on the SNAP DM200.

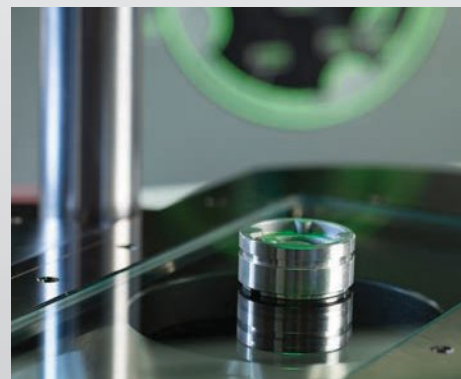
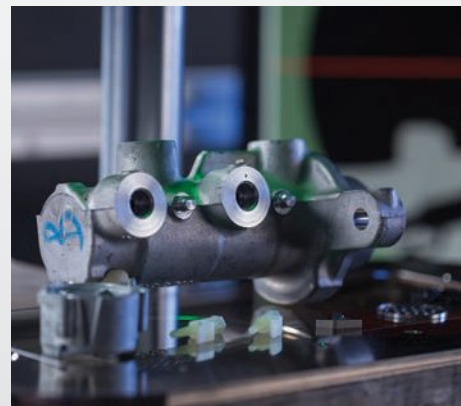
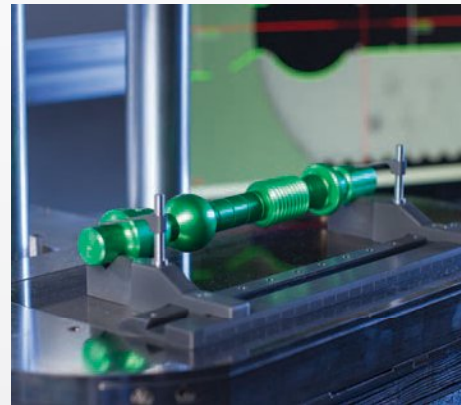
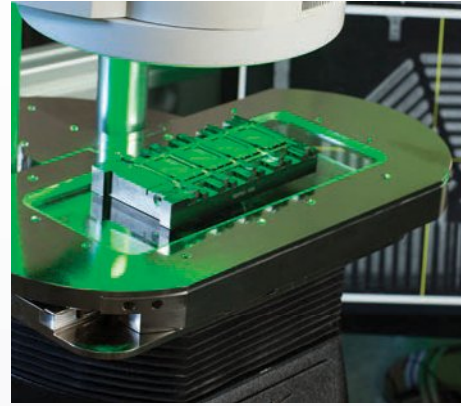
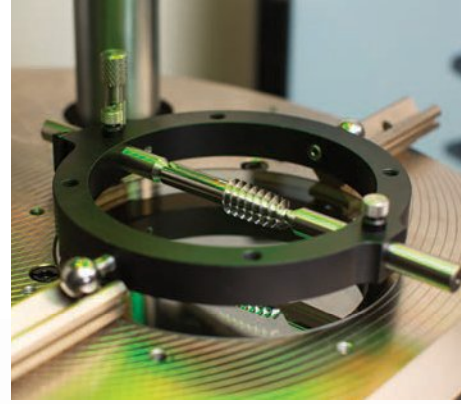
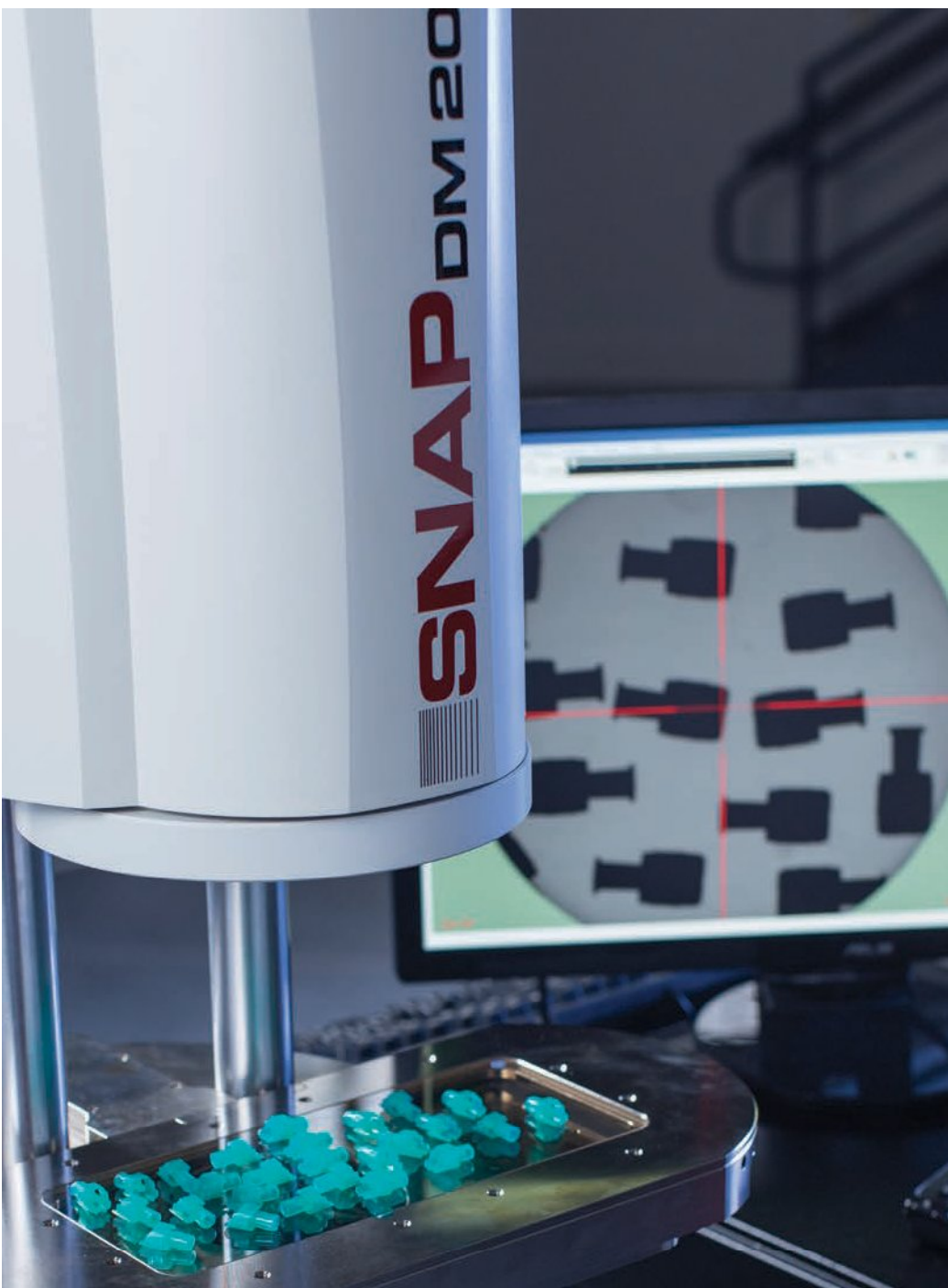

# SNAP Can Measure It

SNAP's large-field-of-view technology, depth of field, and integral software created specifically for SNAP systems allow you to make measurements on virtually any small part.

Digital zooming and SNAP DM200's dual magnification optics allow you to selectively enlarge an image for a closer look at fine features.

Plastics

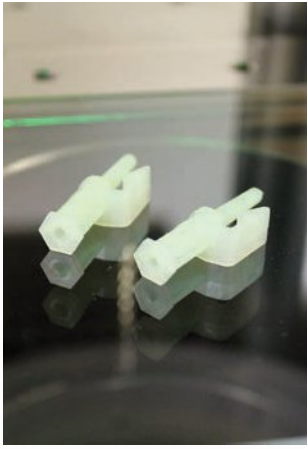

Plastic injection molded parts require the ability to quickly identify and monitor common process variability such as short shot, flash and sink to prevent costly scrap. SNAP systems make spotting and measuring these potential flaws fast and easy.

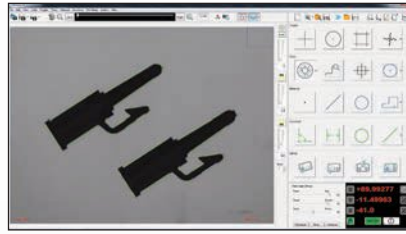

Electronics



Automotive electronic components require fast and accurate measurements to ensure functional performance in automated assembly lines. SNAP systems measure critical part dimensions with ease, even in harsh environments.



Medical



Dimensional integrity is critical for the proper function of medical parts, even disposable items. SNAP systems are the ideal complement to any FDA-compliant medical device manufacturing operation, providing fast, accurate measurements with secure software.

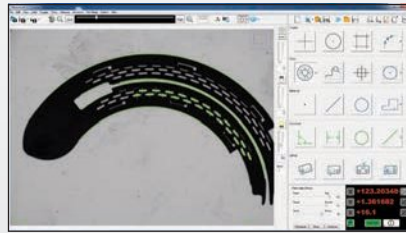

Manufacturing

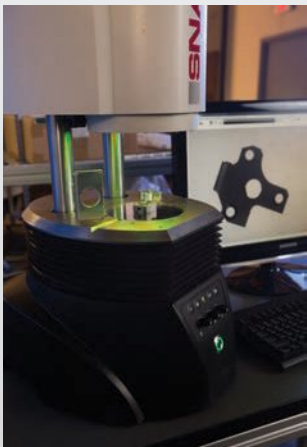

Using QVI large-field-of-view technology, SNAP systems can easily measure machined and formed part features such as holes, counterbores, chamfers, threads, slots and other common machined features. SNAP's rugged construction stands up to machine shop conditions.

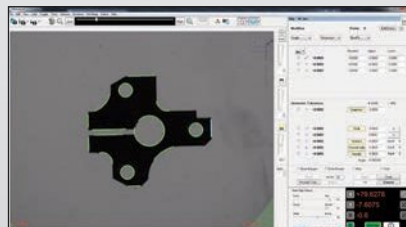

# SNAP Complete Measuring Capability

SNAP offers all the features and functions of an advanced video measuring system in an easy-to-use package.

## Live Output Window

The live output window tracks results and provides instant feedback on any features that are out of tolerance. Tolerance zones and results are also displayed right on the image so you can see details at a glance.

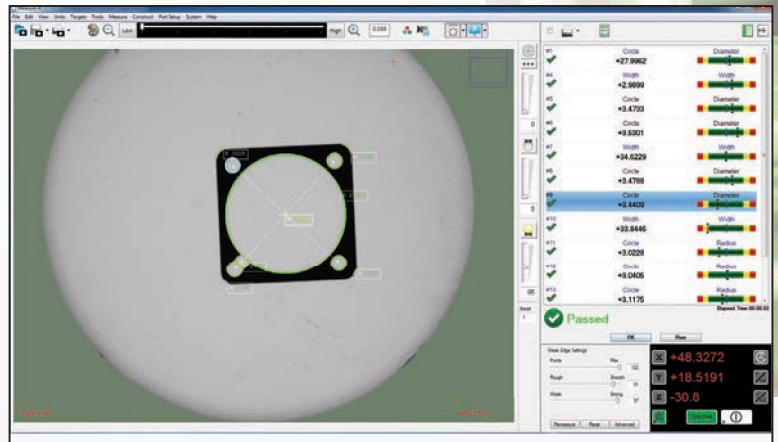

## Automatic Part Identification (AutoID)

SNAP automatically recognizes parts regardless of their orientation. SNAP can AutoID single parts, multiple parts – even a variety of different parts – and run their pre-programmed routines automatically.

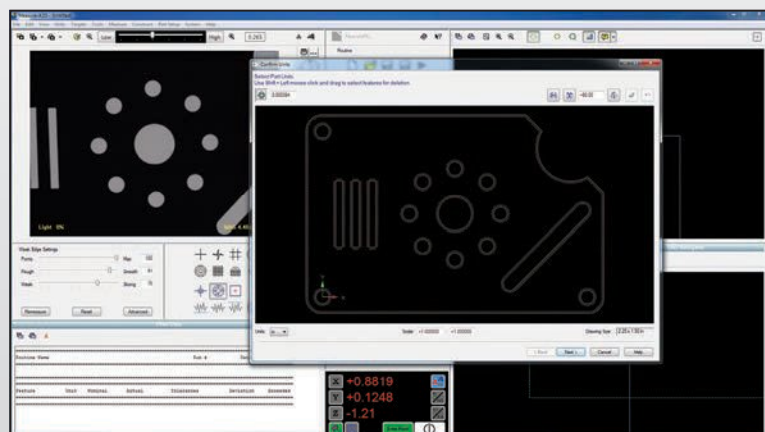
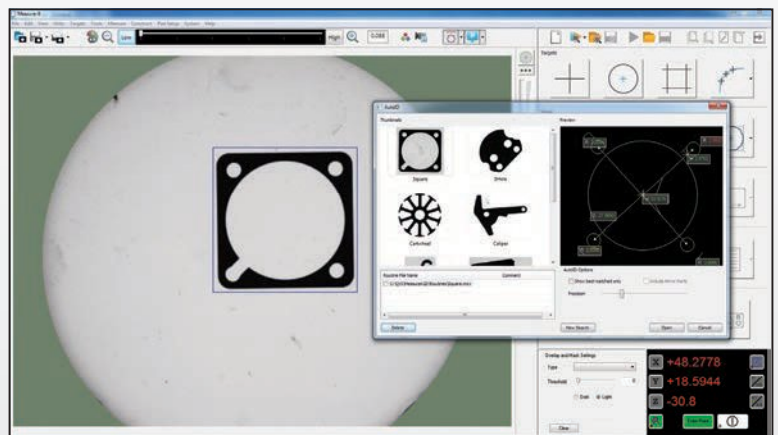

## Simple Routine Setup

SNAP's CAD interface creates measurement routines automatically from the CAD file. Just load the CAD file and select the alignment features. SNAP does the rest. SNAP can handle complex parts with ease. There is no limit to the number of points or steps in a measurement routine.

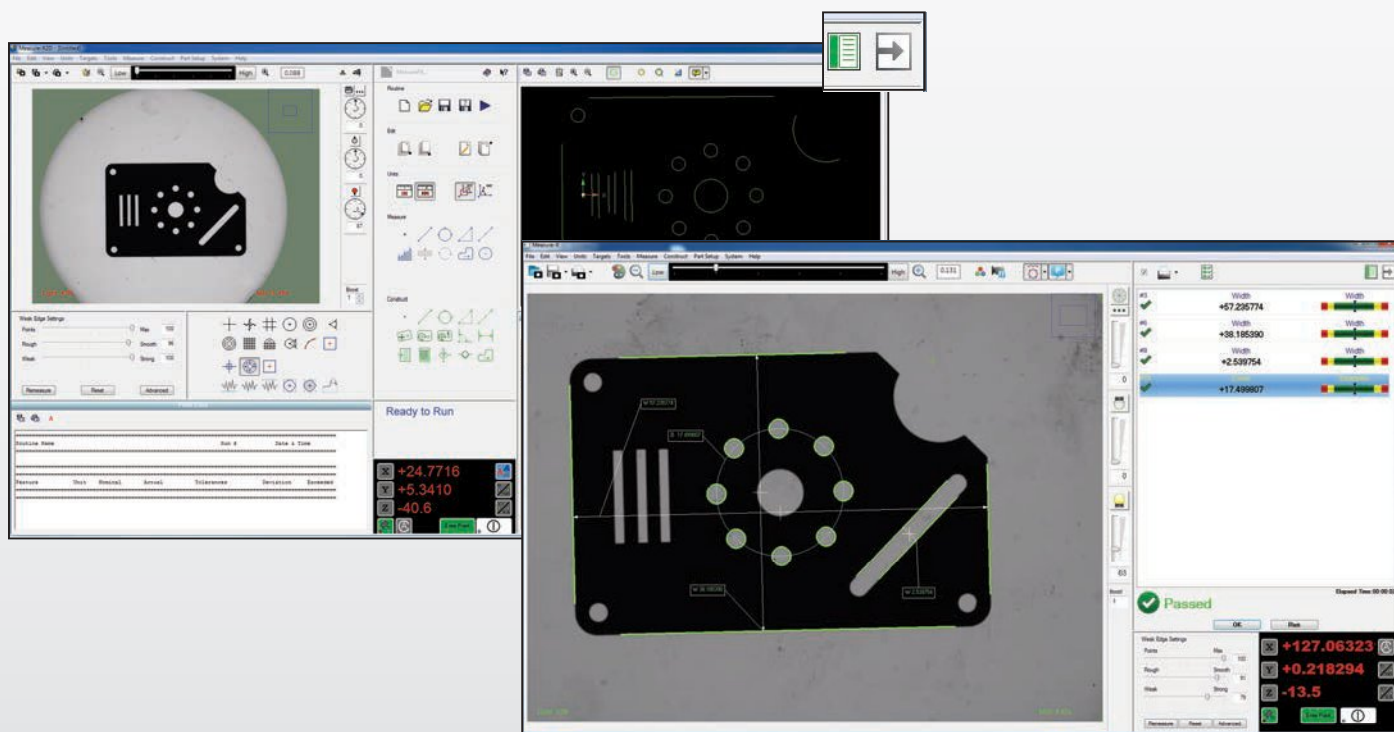

### Choose Your Screen Layout

SNAP offers a choice of screen layouts, allowing you to use the most convenient one for the task at hand. The Core Layout is clean and simple with an oversized live video window and large controls for use with touch screen monitors - ideal for production floor settings. The Full Feature Layout includes all the features that video machine users are familiar with. Just click the icon to toggle between the two layouts.

# Measurements Made Simple

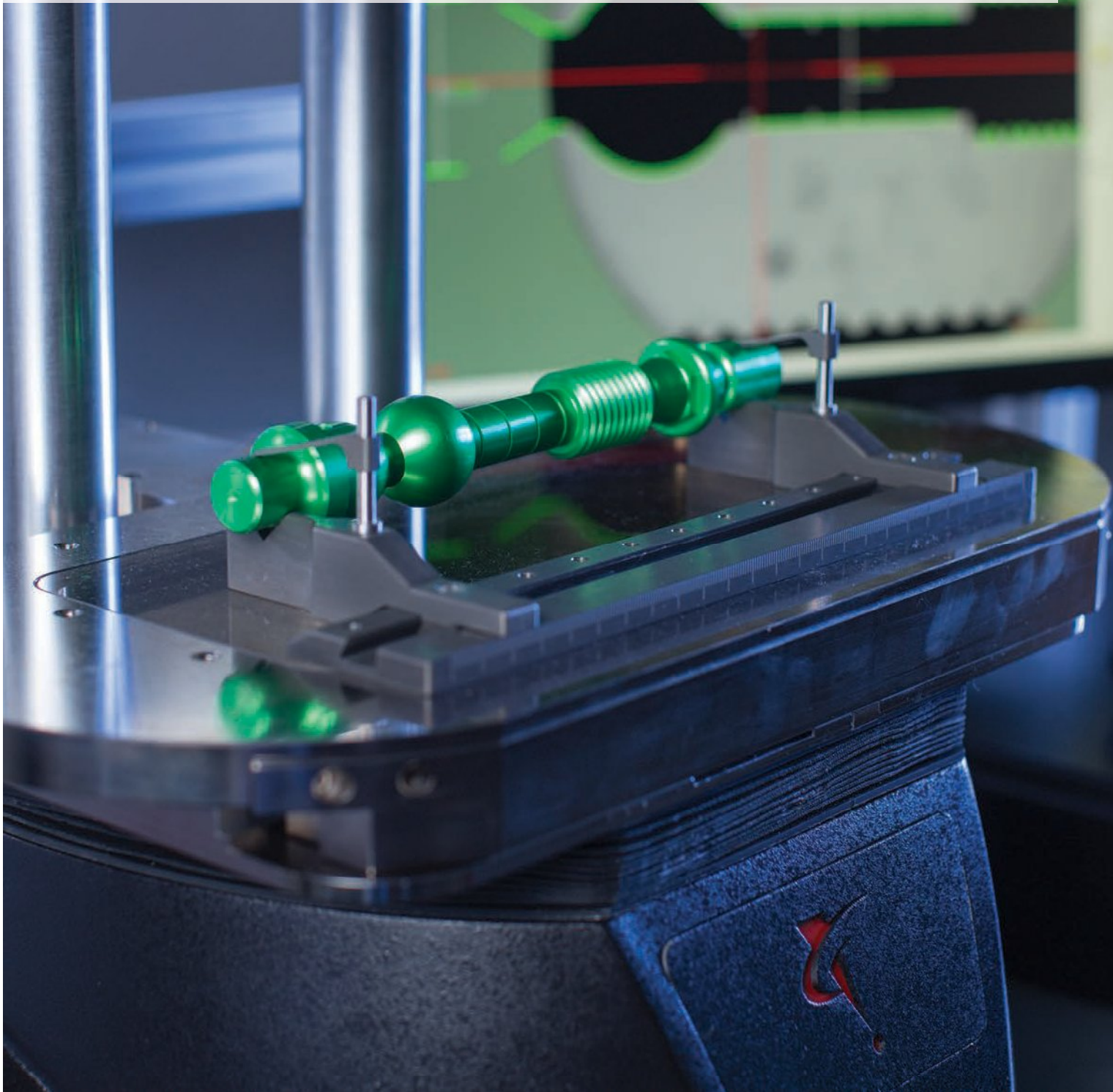

## Calibration Is Easy

A certified field-of-view calibration artifact, traceable to the U.S. National Institute for Standards, is included with each SNAP system and provides a complete error map of the entire field of view for comprehensive feature size calibration. Run calibration yourself – whenever your metrology plan requires it.

SNAP DM200 offers the exclusive built-in AccuCentric® automatic calibration feature to calibrate the centerline reference quickly each time the optical magnification lens is changed.

Stage calibration on the SNAP DM200 is also fully automatic using the optional stage calibration artifact. This makes it easy to perform routine periodic calibration and verification to factory standards.

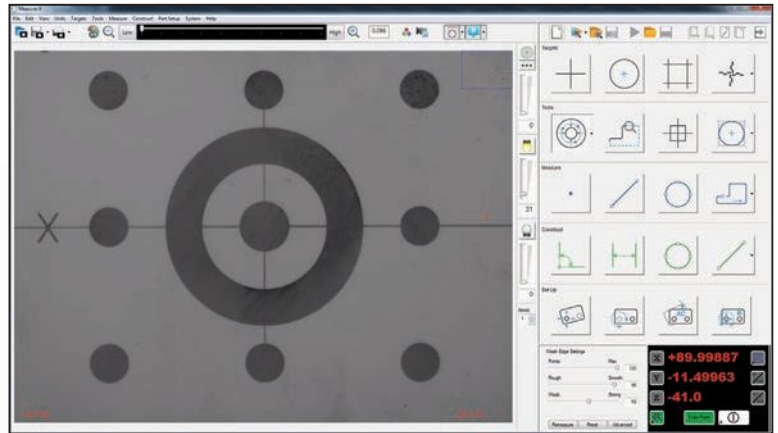

(SNAP Calibration Reticle Shown)

## Options

### SNAP

- Motorized focus motion
- X-axis shuttle stage
- Rotary indexer
- Fixture kits
- Barcode reader
- USB Digital I/O
- Single or dual monitors
- Wired or wireless keyboard & mouse

### SNAP DM200

- High density camera
- Rotary indexer
- Fixture kits
- Stage calibration artifact
- Barcode reader
- USB Digital I/O
- Single or dual monitors
- Wired or wireless keyboard & mouse

## Optional Accessories For Every Measurement

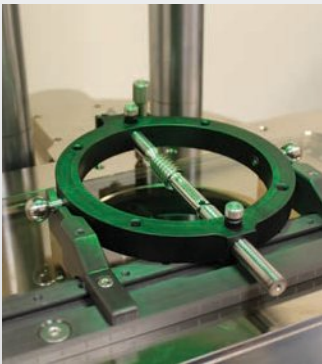

Available fixture kits expand SNAP capability to measure threads and cylindrical parts easily.

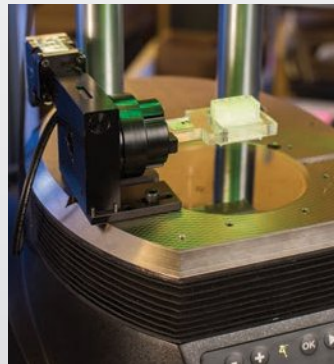

Optional motorized rotary indexers automatically rotate parts to bring features into view for measurement.

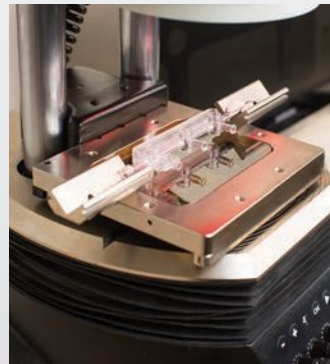

Optional shuttle stage for SNAP systems extends measurement range by an additional 50 mm.

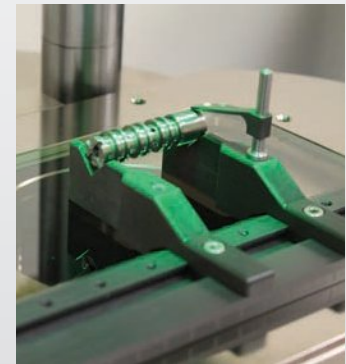

A variety of fixture options are available for convenient part holding.

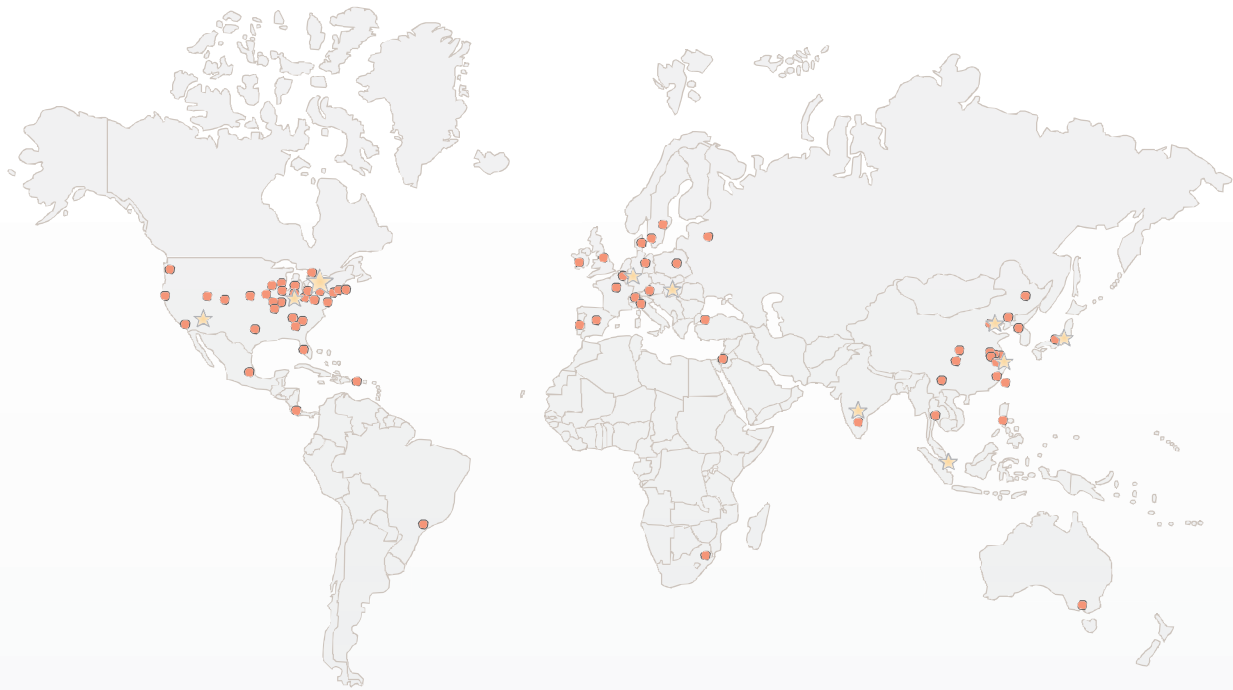

## QUALITY VISION INTERNATIONAL – Precision for People®

Quality Vision International (QVI®) is the world's largest vision metrology company. Founded in 1945, QVI is the world leader in optical, electronic and software technologies for vision and multisensor measuring systems.

Precision for People is more than just our slogan. It's our commitment to delivering our worldwide customers precision metrology systems designed with the people who use them in mind. Precision for People - it's what we stand for.

