

## CC-16 Contour Projector®

Benchtop Optical Comparator



The CC-16 is a top quality optical comparator designed to meet the needs of today's manufacturers. The 16" diameter screen displays crisp, evenly illuminated images at every available magnification.

- Exclusive TruLight® all-LED illumination
- CC-16 is "rock solid" with its cast mineral composite base that provides structural integrity for consistent performance in shop environments
- Optional VidiProbe® video measurement and eCAD® virtual chart gage system

Proudly designed and manufactured in the United States of America



\*Shown with QVI® Q-Check® DRO.



Total Quality Systems Inc.

1783 W. University #135  
Tempe, AZ 85281  
E-Mail sales@tqscorp.com

Inside Sales/Office 480-377-6422  
Fax 480-377-6426  
Todd direct 602-228-3863



# CC-16 Contour Projector

## Available Options and Accessories:

- Extended X-axis travel
- Adjustable direct projection iris
- Digital video screen image capture
- EdgeScan internal automatic edge detection (requires a Quadra-Chek or Q-Touch DRO)
- Projectron automatic grayscale edge detection (requires a Q-Check DRO)
- VidiProbe Video Measurement and Measure-X 2D software
- Fixture and calibration reticles
- Fresnel lens
- Overhead light shield
- Glass and plastic overlay charts
- Heavy duty cabinet stand with storage space
- Ergonomic, motorized adjustable height stand
- Swing away lamphouse
- Service and support contracts

## Optional Software:

- Measure-X<sup>®</sup> 2D Metrology Software
- MeasureFit<sup>®</sup> Plus
- SmartReport<sup>®</sup> with real-time statistics
- Quadra-Chek<sup>®</sup> QC-Wedge (requires Microsoft<sup>®</sup> Excel<sup>™</sup>)
- eCAD<sup>®</sup> for electronic CAD overlay & virtual chart systems
- eChek<sup>™</sup> Metrology Software

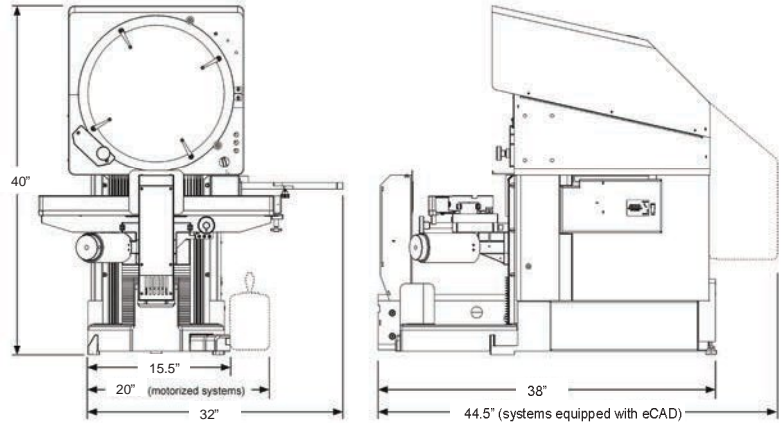

System Weight: 495 lb

	Standard	Optional
<b>XY Travel Range (in)</b>	15 x 6	18 x 6
<b>Helix Angle Range</b>	±7.5° with pivoting worktable assembly and zero stop	
<b>Z Focus Travel (in)</b>	2" with precision fine adjustment	
<b>Throat Clearance (in)</b>	10.75	
<b>XY Scale Resolution (in)</b>	0.00004	0.00002
<b>XY Drive System</b>	Motorized, with variable speed joystick control and manual fine adjustment knobs	
<b>Worktable (in)</b>	Hardcoat anodized aluminum with fixturing slot, 20 x 4.75	
<b>Recommended Maximum Load Capacity (lb)</b>	60	
<b>Optical System</b>	Telecentric with upright, reversed image	
<b>Screen</b>	16" diameter ground glass screen, with integral hood, 90° centerlines and clips for mounting overlay charts	
<b>Protractor</b>	Digital screen display, ± 360° readout with 1' (0.017°) resolution	
<b>Working Distance (in)</b>	3.8	
<b>Lens</b>	10X Projection lens	20X, 31.25X, 50X, 100X
<b>Lens Mount</b>	Internal, quick change lens mount and storage rack with locking access door	Two position lens turret, manual, internal
<b>Illumination</b>	Profile light: High-brightness green LED with continuously variable intensity control	Oblique (Dark Field), Ring Light with 8 white LEDs, 6 switch-selectable patterns for effective directional lighting; continuously variable intensity Through-the-lens coaxial surface light, white brightfield, LED, continuously variable intensity
<b>Electronics</b>	Choice of Quadra-Chek <sup>®</sup> QC-100 or QVI Q-Check <sup>®</sup>	Quadra-Chek QC-200 or QC-300 Q-Touch <sup>™</sup>
<b>Power Requirements</b>	115/230VAC, 50/60 Hz, 1φ, 600W	



**Quality Vision International, Inc.**

Phone: +1 585 758 1300  
 Fax: +1 585 506 4307  
 ccinfo@qvii.com  
 www.qvii.com/ccp

